



Product Data

AquaSnap® 30MPA, MPW015-071 Liquid Chillers with Scroll Compressors and ComfortLink Controls 50/60 Hz

15 to 71 Nominal Tons
(53 to 250 kW)

AQUASNAP®

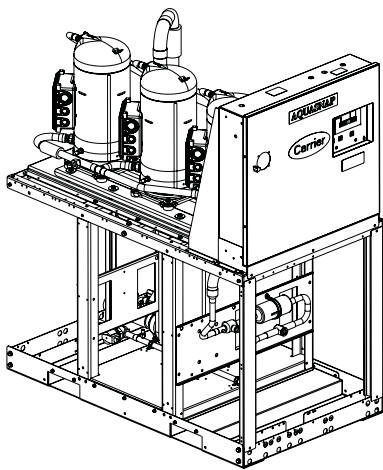

30MPA015-045

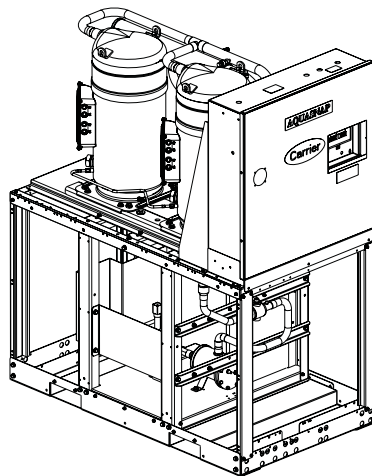

30MPA050-071

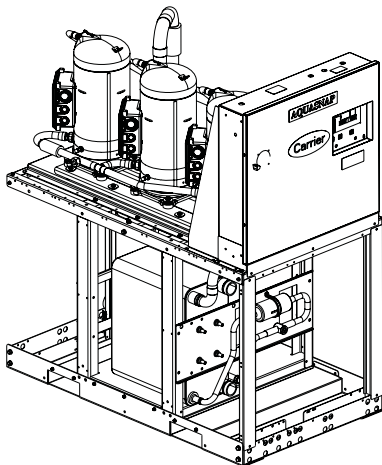

30MPW015-045

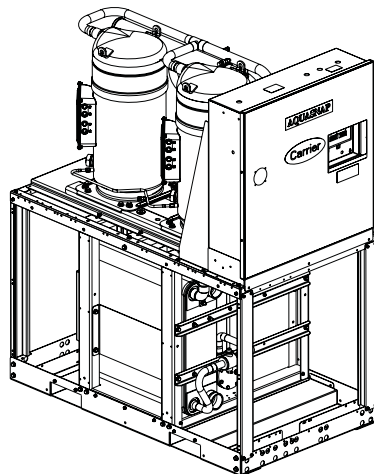

30MPW050-071



SEISMICOMPLIANT*

* Meets IBC 2006, ASCE-7-05, CBC 2007, and OSHPD seismic requirements.

AquaSnap packaged liquid and condenserless chillers feature a rugged, compact modular design for quick and easy installation. This single-circuit modular chiller covers a wide range of applications from ice to heat recovery and various combinations can be easily designed to meet the required plant capacity. Flexible modular design, compact size, and user-friendly controls make the 30MP chillers an optimal choice for reliable cooling.

Value-added features include:

- rotary scroll compression
- HFC Puron® refrigerant (R-410A)
- low sound
- easy to use ComfortLink controls
- application flexibility
- energy efficiency
- modular design
- optional digital scroll compressors

Features/Benefits

Easy to install, scroll chillers offer cost-effective and reliable cooling.

Installation ease

The 30MP units are designed to reduce installation time and costs. They arrive at the jobsite able to fit easily through a standard 36-in. (762 mm) door opening due to their compact design. The 30MP units include fork pockets in the frame for use with forklifts or pallet jacks. Optional mobility and height adjustment kits allow units to quickly roll into place and mate with existing piping. Mobility kit wheels are rubber type, pivot for easy unit maneuvering, and are lockable for safety.

Features/Benefits (cont)



The 30MP height adjustment kit provides a height adjustment mechanism located in each corner of the unit to aid in leveling and facilitate connection to existing piping. The ability to roll the 30MP chiller into most elevators and through most doors combined with the ability to adjust the unit height to match existing piping can significantly lower installation expense.

The 30MP units come complete with an insulated evaporator, condenser (30MPW), compressors, controls, refrigerant charge (30MPW), TXV (thermostatic expansion valve, models 015-045), EXV (electronic expansion valve, models 050-071), filter drier, sight glass, entering and leaving chilled fluid temperature sensors, evaporator water pressure access port, factory-installed evaporator flow switch, and oil charge, and need only the addition of a condenser water supply (30MPW), electrical power, and chilled fluid distribution system. The 30MPA units are designed for use with a remote condenser and include a liquid line isolation valve, liquid line solenoid valve, and have a nitrogen holding charge. The 30MPA chillers may be connected to an air-cooled, evaporative condenser(s) or even liquid condenser(s) sized to meet specific job requirements.

All internal piping and wiring is complete, and since all essential controls and protective devices are installed at the factory, installation is completed in minimal time. The 60-Hz and 50-Hz units are ETL and ETL, Canada listed and conform to ASME (American Society of Mechanical Engineers) standards, simplifying the final inspection process.

Operating reliability and serviceability

The 30MP chiller uses the same compressor sub-assemblies and heat exchangers that are proven to be reliable in AquaSnap® chillers in service around the world. Each unit includes many safeties as standard, including protection from electrical overload, thermal overload, high pressure, low refrigerant charge, and low chilled fluid temperature. A factory-installed thermal dispersion switch containing no moving parts provides reliable low flow and loss of flow protection. Heat exchangers feature ANSI (American

National Standards Institute) 316 stainless steel brazed-plate construction.

The modular design of the 30MP chiller allows units to be installed side by side with no clearance between units to achieve higher capacity. Since each circuit has its own dedicated power supply and controls transformer, an individual chiller can be isolated and serviced while other units continue to operate. The remaining units can provide a supply of chilled water even while a single chiller is down, providing true redundancy and ease of mind.

ComfortLink controls

The *ComfortLink* controls communicate in plain English, making it as easy as possible to monitor and control each AquaSnap chiller while accurately maintaining fluid temperatures. The large scrolling marquee display acts as a window into the unit's operation, providing easy-to-read information about chiller performance and over 15 diagnostic functions. The Carrier 30 Series chillers' *ComfortLink* controls provide features such as chilled water temperature reset, compressor wear minimization and protection. They also display temperature, pressure and other valuable unit operating information.

The 30MP chillers employ more than the latest advanced microprocessor controls, they utilize an expandable platform that can adjust as needs change. *ComfortLink* controls are used in diverse applications from stand-alone operation to remotely monitored and operated multi-chiller plants. The scrolling marquee display also features Spanish, French, and Portuguese languages. A BACnet* communication option is also available for the i-Vu® Open control system or a BACnet building automation system.

Operating efficiency and flexibility

The 30MP chillers exceed ASHRAE (American Society of Heating, Refrigerating, and Air-Conditioning Engineers) 90.1 minimum efficiency requirements. At full load, 30MP chillers can provide efficiencies better than 0.750 kW/ton at AHRI (Air-Conditioning, Heating, and Refrigeration Institute) standard conditions. The 30MP chillers use ultra-quiet, high-efficiency scroll compressors, operated in tandem or trio for greater efficiency at

partial loads. The 30MP chillers can also be operated with variable flow, allowing building owners to realize even greater overall system energy savings in the chilled water pumping system.

The 30MP chillers also feature a wide, flexible operating range. Standard units can provide up to 140 F (60.0 C) leaving condenser water temperature for heat recovery applications (high condensing is a selectable option on models 050-071) while chillers equipped with the medium temperature brine option can provide leaving chilled fluid temperatures down to 15 F (-9.4 C) for ice build and process cooling. (The 30MP unit controls to a leaving chilled water set point; to control to a leaving condenser water set point, external controls will be required.) Units have the capability to start and pull down with up to 95 F (35 C) entering-fluid temperature due to the integral pressure limiting feature of the expansion valve.

Whether in the classroom, on the production floor, or in the office, *ComfortLink* controls can assist in adaptation to changing weather and business conditions. Accurate temperature control, provided by Carrier's *ComfortLink* system, helps to maintain higher levels of indoor air quality, thermal comfort, and space productivity. While many chillers use only leaving fluid temperature control, the 30MP chillers utilize leaving fluid temperature control with entering fluid temperature compensation. This Carrier exclusive provides smart control and intelligent machine capacity staging.

Energy management made easy

While 30MP chillers have many standard features, such as network communications capability and temperature reset based on return fluid temperature, they can also expand as needs change. Supply temperature reset based on outside air or space temperature is as easy as adding a thermistor. The energy management option allows use of changing utility rate structures with easy to use load shedding, demand limiting and temperature reset capabilities. Reset triggered via a 4 to 20 mA signal (requires EMM [energy management module] option) makes integrating from an existing building management system simple.

*Sponsored by ASHRAE (American Society of Heating, Refrigerating and Air-Conditioning Engineers).

Digital scroll compressors (models 020-045 only)

Digital scroll compressors are available as a factory-installed option. These compressors allow incremental

unloading with capacity modulation to better match building load when compared to standard scroll compressors.

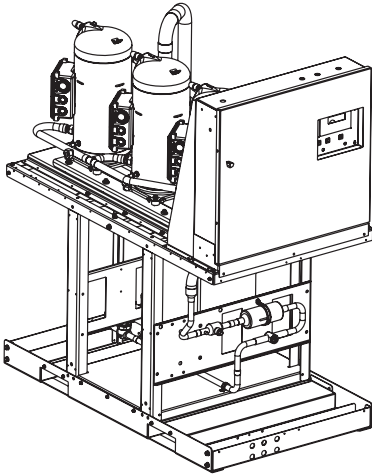

30MP COMPACT SIZE

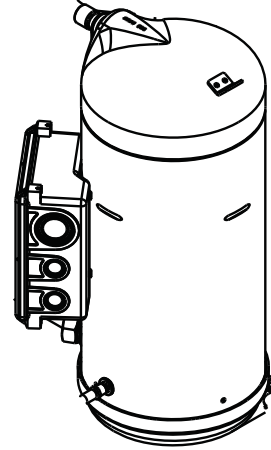

SCROLL COMPRESSOR

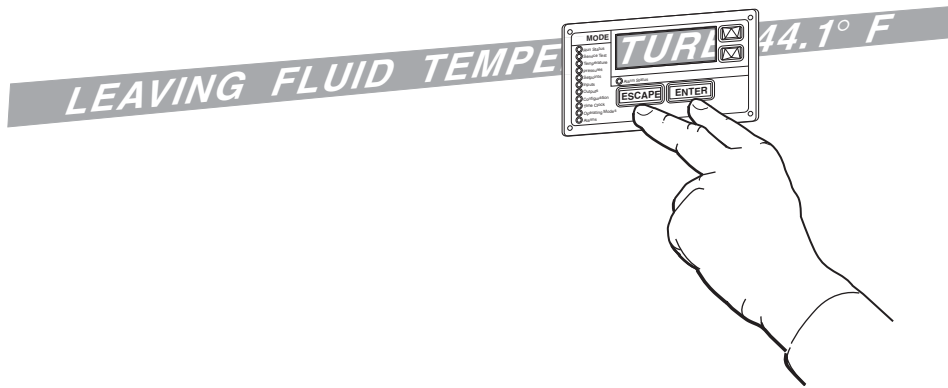

SCROLLING MARQUEE CLEAR LANGUAGE DISPLAY

Table of contents

	Page
Features/Benefits	1-3
Model Number Nomenclature	4
AHRI Capacity Ratings	5
Physical Data	6-9
Options and Accessories	10,11
Dimensions	12-21
Application Data	22-26
Selection Procedure	27
Performance Data	28-33
Electrical Data	34-36
Controls	37,38
Typical Piping and Wiring	39-42
Typical Control Wiring Schematic	43
Guide Specifications	44-47

Model number nomenclature



30MP A 030 6 0 - 0 0 0 0 5

30MP – AquaSnap® Liquid Chiller with *ComfortLink* Controls

Condenser Option

- A** – Chiller without Condenser (Air-Cooled)
- W** – Chiller with Condenser (Water-Cooled)

Unit Size – Nominal Tons (kW)

- 015** – 15 (53) **050** – 50 (176)
- 020** – 20 (70) **055** – 55 (194)
- 030** – 30 (106) **060** – 60 (211)
- 040** – 40 (141) **065** – 65 (229)
- 045** – 45 (158) **071** – 71 (250)

Voltage Options

- 1** – 575-3-60
- 2** – 380-3-60
- 5** – 208/230-3-60
- 6** – 460-3-60
- 9** – 380/415-3-50

Sound/Mounting Options

- 0** – None
- 1** – Sound Enclosure Panels
- 2** – Water Manifold Sound Enclosure Panels
- 3** – Height Adjustment Kit
- 4** – Height Adjustment Kit, Sound Enclosure Panels
- 5** – Height Adjustment Kit, Water Manifold Sound Enclosure Panels
- 9** – Mobility Kit (Wheels)
- B** – Mobility Kit (Wheels), Sound Enclosure Panels
- C** – Mobility Kit (Wheels), Water Manifold Sound Enclosure Panels
- D** – Height Adjustment Kit, Mobility Kit (Wheels)
- F** – Height Adjustment Kit, Mobility Kit (Wheels), Sound Enclosure Panels
- G** – Height Adjustment Kit, Mobility Kit (Wheels), Water Manifold Sound Enclosure Panels
- L** – Compressor Sound Blankets
- M** – Compressor Sound Blankets, Mobility Kit (Wheels)
- N** – Compressor Sound Blankets, Height Adjustment Kit
- P** – Compressor Sound Blankets, Mobility Kit (Wheels), Height Adjustment Kit

Packaging Options

- 5** – Bag, No Compressor Insulation (Std)
- 7** – Bag, Compressor Insulation
- B** – Export Crating, No Compressor Insulation
- D** – Export Crating, Compressor Insulation

Controls/Interface Options

- 0** – Scrolling Marquee Display (Std)
- 1** – Scrolling Marquee Display with BACnet Communication Option
- 5** – Scrolling Marquee Display, EMM
- 6** – Scrolling Marquee Display with BACnet Communication Option and EMM

Disconnect Options

- 0** – Standard (Terminal Block)
- 1** – Non-Fused Disconnect Switch

Capacity Control/High Interrupt Options

- 0** – Standard
- 1** – Hot Gas Bypass
- 2** – Digital Compressor*
- 3** – High Interrupt
- 4** – High Interrupt and Hot Gas Bypass
- 5** – High Interrupt and Digital Compressor
- 6** – High Condensing†
- 7** – High Condensing† and Hot Gas Bypass
- 8** – High Interrupt and High Condensing†
- 9** – High Interrupt, High Condensing†, and Hot Gas Bypass

Water Manifold/Brine Options

- 0** – Comfort Cooling Duty (32-60 F) (0.0°-16.5 C) (Std)
- 1** – Water Manifold Piping (Includes Combination Valve)
- 7** – Medium Temperature Brine (15-32 F) (-9.4-0.0° C)
- 8** – Water Manifold Piping (Includes Combination Valve), Medium Temperature Brine

Design Revision Level

- - Initial Release

LEGEND

EMM — Energy Management Module

*Digital compressor available on models 020-045 only.
 †High condensing available on models 050-071 only.

Quality Assurance

Certified to ISO 9001

AHRI capacity ratings



AHRI RATINGS (60 Hz)

UNIT 30	CAPACITY		INPUT POWER (kW)	EVAPORATOR FLOW		EVAPORATOR PRESSURE DROP		CONDENSER FLOW		CONDENSER PRESSURE DROP		EER	FULL LOAD		IPLV	
	Tons	kW		Gpm	L/s	Ft of Water	kPa	Gpm	L/s	Ft of Water	kPa		lkW/Ton	COP	lkW/Ton	COP
MPW015	15.6	54.7	12.4	37.4	2.4	11.0	32.9	46.7	2.9	12.2	36.5	15.1	0.795	4.43	0.564	6.24
MPW020	20.7	72.8	15.6	49.8	3.1	14.9	44.6	62.2	3.9	16.8	50.2	15.9	0.753	4.67	0.585	6.01
MPW030	31.0	109.1	23.6	74.5	4.7	13.6	40.7	93.1	5.9	17.1	51.1	15.8	0.760	4.63	0.578	6.08
MPW040	39.9	140.4	30.2	95.9	6.1	10.3	30.8	119.8	7.6	18.8	56.2	15.9	0.756	4.65	0.560	6.28
MPW045	46.6	163.8	35.1	111.9	7.1	12.4	37.1	139.9	8.8	16.5	49.3	15.9	0.753	4.67	0.568	6.20
MPW050	51.4	179.9	37.8	123.3	7.7	11.6	34.6	154.2	9.9	12.9	35.6	16.3	0.735	4.79	0.472	7.45
MPW055	58.3	205.0	43.6	140.0	8.8	14.6	43.7	175.0	11.0	16.4	45.1	16.0	0.748	4.70	0.464	7.58
MPW060	60.9	214.1	45.1	146.0	9.3	14.0	41.9	182.6	11.7	13.6	40.6	16.2	0.741	4.75	0.474	7.42
MPW065	65.4	230.0	48.6	157.1	10.1	16.0	47.9	196.3	12.6	15.5	46.4	16.1	0.743	4.73	0.476	7.40
MPW071	72.1	252.2	54.0	172.9	11.1	14.8	44.3	216.2	13.8	18.5	55.4	16.0	0.749	4.70	0.485	7.25

LEGEND

AHRI — Air-Conditioning, Heating and Refrigeration Institute
COP — Coefficient of Performance
EER — Energy Efficiency Ratio
lkW — Input Kilowatt
IPLV — Integrated Part Load Value

NOTES:

- The 60 Hz units are certified in accordance with AHRI Standard 550/590 and 551/591 at standard rating conditions.
- Standard rating conditions are as follows:
 Evaporator Conditions:
 Leaving Water Temperature: 44 F (6.7 C)
 Flow: 2.4 gpm per ton (0.043 L/s per kW)
 Condenser Conditions:
 Entering Water Temperature: 85 F (29.4 C)
 Flow: 3.0 gpm per ton (0.054 L/s per kW)

Fouling Factor (Evaporator):

0.00010 hr x sq ft x F per Btu (0.000018 m² x K per W)

Fouling Factor (Condenser):

0.00025 hr x sq ft x F per Btu (0.000044 m² x K per W)

- IPLV is a single number part load efficiency value calculated from the system full load efficiency values and corrected for a typical building air-conditioning application.
- All data in the above table was generated in Packaged Chiller Builder version 3.49k. Refer to the most current version of the Packaged Chiller Builder for the most up-to-date data.
- Contact Carrier for custom ratings or for 30MPA remote air-cooled unit ratings.



PERFORMANCE RATINGS (50 Hz)

UNIT 30	CAPACITY		INPUT POWER (kW)	EVAPORATOR FLOW		EVAPORATOR PRESSURE DROP		CONDENSER FLOW		CONDENSER PRESSURE DROP		EER	FULL LOAD		IPLV	
	Tons	kW		Gpm	L/s	Ft of Water	kPa	Gpm	L/s	Ft of Water	kPa		lkW/Ton	COP	lkW/Ton	COP
MPW015	13.0	45.6	10.3	31.3	2.0	8.4	25.1	39.1	2.4	8.1	24.2	15.2	0.790	4.45	0.549	6.07
MPW020	17.5	61.4	13.4	42.0	2.7	11.4	34.1	52.5	3.3	11.4	34.1	15.6	0.766	4.59	0.539	5.96
MPW030	25.9	91.0	20.1	62.0	4.0	10.2	29.8	77.7	4.9	11.6	34.6	15.4	0.775	4.54	0.562	6.26
MPW040	32.9	115.7	25.3	78.8	5.1	7.6	22.7	98.6	6.2	12.0	35.9	15.5	0.770	4.57	0.553	6.36
MPW045	39.0	137.1	30.0	93.4	6.0	9.4	28.1	116.9	7.3	10.9	32.6	15.5	0.770	4.57	0.541	6.50
MPW050	43.2	151.2	29.9	103.7	6.6	8.4	25.2	129.6	8.3	9.3	25.7	17.3	0.693	5.07	0.437	8.04
MPW055	48.8	170.8	35.3	117.2	7.5	10.5	31.5	146.5	9.4	11.7	32.3	16.6	0.723	4.86	0.442	7.95
MPW060	50.6	180.0	36.6	121.5	7.8	10.0	29.9	151.9	9.7	9.7	29.0	16.6	0.722	4.87	0.437	8.05
MPW065	53.6	190.1	39.0	128.7	8.2	11.1	33.2	160.9	10.3	10.8	32.2	16.5	0.727	4.84	0.447	7.87
MPW071	61.7	216.6	45.2	148.2	9.5	11.3	33.8	185.2	11.9	14.0	41.7	16.4	0.731	4.81	0.459	7.66

LEGEND

AHRI — Air-Conditioning, Heating and Refrigeration Institute
COP — Coefficient of Performance
EER — Energy Efficiency Ratio
lkW — Input Kilowatt
IPLV — Integrated Part Load Value

NOTES:

- The 50 Hz units are rated in accordance with AHRI, but are not considered part of the AHRI water-cooled chiller certification program.
- Standard rating conditions are as follows:
 Evaporator Conditions:
 Leaving Water Temperature: 44 F (6.7 C)
 Flow: 2.4 gpm per ton (0.043 L/s per kW)

Condenser Conditions:

Entering Water Temperature: 85 F (29.4 C)
 Flow: 3.0 gpm per ton (0.054 L/s per kW)

Fouling Factor (Evaporator):

0.00010 hr x sq ft x F per Btu (0.000018 m² x K per W)

Fouling Factor (Condenser):

0.00025 hr x sq ft x F per Btu (0.000044 m² x K per W)

- IPLV is a single number part load efficiency value calculated from the system full load efficiency values and corrected for a typical building air-conditioning application.
- All data in the above table was generated in Packaged Chiller Builder version 3.49k. Refer to the most current version of the Packaged Chiller Builder for the most up-to-date data.
- Contact Carrier for custom ratings or for 30MPA remote air-cooled unit ratings.

Physical data



30MPA AIR-COOLED AND 30MPW LIQUID-COOLED UNITS — ENGLISH

UNIT 30MPA,MPW	015	020	030	040	045
NOMINAL TONS	15	20	30	40	45
OPERATING WT (lb)					
MPA	626	635	721	912	934
MPA with Manifold	829	838	925	1116	1137
MPW	680	704	860	1097	1190
MPW with Manifold	1085	1109	1267	1504	1595
REFRIGERANT (lb)			R-410A		
MPA*	8.2	10.7	12.5	14.7	15.1
MPW	11.8	15.3	21.0	27.3	34.5
COMPRESSOR			Scroll, Hermetic		
Quantity	2	2	2	3	3
Speed (rpm, 60 Hz/50 Hz)	3500/2900	3500/2900	3500/2900	3500/2900	3500/2900
Compressor Nominal Tons	7.5	10	15	13	15
Oil Charge (pt)	10.6	13.8	13.8	20.6	20.6
Capacity Control — Standard					
No. of Steps	2	2	2	3	3
Minimum Step Capacity (%)	50	50	50	33	33
Capacity Control — Optional Hot Gas Bypass					
No. of Steps	3	3	3	4	4
Minimum Step Capacity (%)	18	25	34	21	22
Capacity Control — Optional Digital Compressor					
No. of Steps	—	22	22	33	33
Minimum Step Capacity (%)	—	15	15	10	10
EVAPORATOR					
Weight (lb, empty)	27.5	40.3	91.8	122.3	128.3
Net Fluid Volume (gal.)	0.8	1.2	2.4	3.2	3.4
Maximum Refrigerant Pressure (psig)	505	505	565	565	565
Maximum Fluid-Side Pressure (psig)	300	300	300	300	300
Evaporator Connections (in.)					
Inlet and Outlet (Victaulic IPS)	2	2	2 1/2	2 1/2	2 1/2
Drain (NPT)	1/2	1/2	1/2	1/2	1/2
Manifold Connections (in.)					
Inlet and Outlet (Victaulic IPS)	6	6	6	6	6
CONDENSER (30MPW Only)					
Weight (lb, empty)	34.9	43.6	104.6	136.7	188.3
Net Fluid Volume (gal.)	1.2	1.6	2.9	4.1	5.9
Maximum Refrigerant Pressure (psig)	505	505	565	565	565
Maximum Water-Side Pressure (psig)	300	300	300	300	300
Condenser Connections (in.)					
Inlet and Outlet (Victaulic IPS)	1 1/2	1 1/2	2	2	2
Manifold Connections (in.)					
Inlet and Outlet (Victaulic IPS)	6	6	6	6	6
CONDENSER REFRIGERANT CONNECTIONS (30MPA Only)					
Liquid Line (ODS) (in.)	1/2	1/2	5/8	5/8	5/8
Discharge Line (ODS) (in.)	1 3/8	1 3/8	1 3/8	1 5/8	1 5/8
CHASSIS DIMENSIONS (in.)					
Length	55	55	55	55	55
Width	32	32	32	32	32
Height	62.5	62.5	62.5	62.5	62.5
MINIMUM SYSTEM FLUID VOLUME (gal. per Ton)					
Normal Air Conditioning					
Standard	6	6	6	3	3
Optional Hot Gas Bypass	4	4	4	3	3
Optional Digital Compressor	—	3	3	3	3
Low Outdoor Ambient Cooling Operation (30MPA Units)					
Standard	10	10	10	6	6
Optional Hot Gas Bypass	10	10	10	6	6
Optional Digital Compressor	—	6	6	6	6
CAPACITY STEPS					
Step 1	100%	100%	100%	100%	100%
Step 2	50%	50%	50%	67%	67%
Step 3	18%†	25%†	34%†	33%	33%
Step 4	—	—	—	21%†	22%†
MINIMUM FLOW RATES (gpm)					
Evaporator	22	28	43	55	64
Condenser	22	28	43	55	64
MAXIMUM FLOW RATES (gpm)					
Evaporator	74	97	148	188	220
Condenser	74	97	148	188	220

* 30MPA units (condenserless) are shipped with nitrogen holding charge. Approximate cooler operating charge is shown.
 † With optional hot gas bypass.

NOTES:

1. Operating weight includes refrigerant operating charge and weight of fluid in the heat exchangers.
2. Manifold option adds approximately 203 lb to the operating weight of MPA units and 405 lb to the operating weight of MPW units.
3. 30MPW units are shipped with full operating charge.

30MPA AIR-COOLED AND 30MPW LIQUID-COOLED UNITS — ENGLISH (cont)

UNIT 30MPA,MPW	050	055	060	065	071
NOMINAL TONS	50	55	60	65	71
OPERATING WT (lb)					
MPA	1398	1413	1437	1468	1506
MPA with Manifold	1616	1631	1655	1686	1724
MPW	1602	1617	1681	1712	1719
MPW with Manifold	2038	2053	2117	2148	2155
REFRIGERANT (lb)					
	R-410A				
MPA*	29.7	30.7	33.1	34.0	39.0
MPW	43.2	44.6	47.9	49.3	50.1
COMPRESSOR					
	Scroll, Hermetic				
Quantity	2	2	2	2	2
Speed (rpm, 60 Hz/50 Hz)	3500/2900	3500/2900	3500/2900	3500/2900	3500/2900
Compressor Nominal Tons (A1, A2)	25,25	25,32	25,35	25,40	32,40
Oil Charge (pt)	22.4	22.4	22.4	22.4	22.4
Capacity Control — Standard					
No. of Steps	2	2	2	2	2
Minimum Step Capacity (%)	50	44	42	38	44
Capacity Control — Optional Hot Gas Bypass					
No. of Steps	3	3	3	3	3
Minimum Step Capacity (%)	40	35	33	31	38
Capacity Control — Optional Digital Compressor					
No. of Steps	—	—	—	—	—
Minimum Step Capacity (%)	—	—	—	—	—
EVAPORATOR					
Weight (lb, empty)	143	143	167	167	190
Net Fluid Volume (gal.)	3.9	3.9	4.7	4.7	5.4
Maximum Refrigerant Pressure (psig)	653	653	653	653	653
Maximum Fluid-Side Pressure (psig)	300	300	300	300	300
Evaporator Connections (in.)					
Inlet and Outlet (Victaulic IPS)	2 ¹ / ₂	2 ¹ / ₂	2 ¹ / ₂	2 ¹ / ₂	2 ¹ / ₂
Drain (NPT)	1/2	1/2	1/2	1/2	1/2
Manifold Connections (in.)					
Inlet and Outlet (Victaulic IPS)	6	6	6	6	6
CONDENSER (30MPW Only)					
Weight (lb, empty)	204	204	244	244	244
Net Fluid Volume (gal.)	5.2	5.2	6.3	6.3	6.3
Maximum Refrigerant Pressure (psig)	653	653	653	653	653
Maximum Water-Side Pressure (psig)	300	300	300	300	300
Condenser Connections (in.)					
Inlet and Outlet (Victaulic IPS)	2 ¹ / ₂	2 ¹ / ₂	2 ¹ / ₂	2 ¹ / ₂	2 ¹ / ₂
Drain (NPT)	—	—	—	—	—
Manifold Connections (in.)					
Inlet and Outlet (Victaulic IPS)	6	6	6	6	6
CONDENSER REFRIGERANT CONNECTIONS (30MPA Only)					
Liquid Line (ODS) (in.)	1 ¹ / ₈	1 ¹ / ₈	1 ¹ / ₈	1 ¹ / ₈	1 ¹ / ₈
Discharge Line (ODS) (in.)	1 ⁵ / ₈	1 ⁵ / ₈	1 ⁵ / ₈	1 ⁵ / ₈	1 ⁵ / ₈
CHASSIS DIMENSIONS (in.)					
Length	55	55	55	55	55
Width	32	32	32	32	32
Height	66.34	66.34	66.34	66.34	66.34
MINIMUM SYSTEM FLUID VOLUME (gal. per Ton)					
Normal Air Conditioning					
Standard	6	6	6	6	6
Optional Hot Gas Bypass	4	4	4	4	4
Optional Digital Compressor	—	—	—	—	—
Low Outdoor Ambient Cooling Operation					
Standard	10	10	10	10	10
Optional Hot Gas Bypass	10	10	10	10	10
Optional Digital Compressor	—	—	—	—	—
CAPACITY STEPS					
Step 1	100%	100%	100%	100%	100%
Step 2	50%	44%	42%	38%	44%
Step 3	40%†	35%†	33%†	31%†	38%†
Step 4	—	—	—	—	—
MINIMUM FLOW RATES (gpm)					
Evaporator	70	77	84	91	104
Condenser	70	77	84	91	104
MAXIMUM FLOW RATES (gpm)					
Evaporator	238	262	286	309	354
Condenser	238	262	286	309	354

* 30MPA units (condenserless) are shipped with nitrogen holding charge. Approximate cooler operating charge is shown.
 † With optional hot gas bypass.

NOTES:

1. Operating weight includes refrigerant operating charge and weight of fluid in the heat exchangers.
2. Manifold option adds approximately 218 lb to the operating weight of MPA units and 436 lb to the operating weight of MPW units.
3. 30MPW units are shipped with full operating charge.

Physical data (cont)



30MPA AIR-COOLED AND 30MPW LIQUID-COOLED UNITS — SI

UNIT 30MPA,MPW	015	020	030	040	045
NOMINAL kW	53	70	106	141	158
OPERATING WT (kg)					
MPA	284	288	327	414	424
MPA with Manifold	377	381	421	507	517
MPW	308	319	390	498	540
MPW with Manifold	493	504	576	684	725
REFRIGERANT (kg)			R-410A		
MPA*	3.7	4.9	5.7	6.7	6.8
MPW	5.3	6.9	9.5	12.4	15.6
COMPRESSOR			Scroll, Hermetic		
Quantity	2	2	2	3	3
Speed (r/s, 60 Hz/50 Hz)	58/48	58/48	58/48	58/48	58/48
Compressor Nominal kW	26	35	53	45	53
Oil Charge (L)	5.0	6.5	6.5	9.8	9.8
Capacity Control — Standard					
No. of Steps	2	2	2	3	3
Minimum Step Capacity (%)	50	50	50	33	33
Capacity Control — Optional Hot Gas Bypass					
No. of Steps	3	3	3	4	4
Minimum Step Capacity (%)	18	25	34	21	22
Capacity Control — Optional Digital Compressor					
No. of Steps	—	22	22	33	33
Minimum Step Capacity (%)	—	15	15	10	10
EVAPORATOR					
Weight (kg, empty)	12.5	18.3	41.6	55.5	58.2
Net Fluid Volume (L)	2.9	4.6	8.9	12.0	13.0
Maximum Refrigerant Pressure (kPa)	3482	3482	3896	3896	3896
Maximum Fluid-Side Pressure (kPa)	2068	2068	2068	2068	2068
Evaporator Connections (in.)					
Inlet and Outlet (Victaulic IPS)	2	2	2 1/2	2 1/2	2 1/2
Drain (NPT)	1/2	1/2	1/2	1/2	1/2
Manifold Connections (in.)					
Inlet and Outlet (Victaulic IPS)	6	6	6	6	6
CONDENSER (30MPW Only)					
Weight (kg, empty)	15.8	19.8	47.4	62.0	85.4
Net Fluid Volume (L)	4.5	5.9	11.1	15.4	22.4
Maximum Refrigerant Pressure (kPa)	3482	3482	3896	3896	3896
Maximum Water-Side Pressure (kPa)	2068	2068	2068	2068	2068
Condenser Connections (in.)					
Inlet and Outlet (Victaulic IPS)	1 1/2	1 1/2	2	2	2
Manifold Connections (in.)					
Inlet and Outlet (Victaulic IPS)	6	6	6	6	6
CONDENSER REFRIGERANT CONNECTIONS (30MPA Only)					
Liquid Line (ODS) (in.)	1/2	1/2	5/8	5/8	5/8
Discharge Line (ODS) (in.)	1 3/8	1 3/8	1 3/8	1 5/8	1 5/8
CHASSIS DIMENSIONS (mm)					
Length	1397	1397	1397	1397	1397
Width	813	813	813	813	813
Height	1588	1588	1588	1588	1588
MINIMUM SYSTEM FLUID VOLUME (L per kW)					
Normal Air Conditioning					
Standard	6.5	6.5	6.5	3.3	3.3
Optional Hot Gas Bypass	4.3	4.3	4.3	3.3	3.3
Optional Digital Compressor	—	3.3	3.3	3.3	3.3
Low Outdoor Ambient Cooling Operation (30MPA Units)					
Standard	10.8	10.8	10.8	6.5	6.5
Optional Hot Gas Bypass	10.8	10.8	10.8	6.5	6.5
Optional Digital Compressor	—	6.5	6.5	6.5	6.5
CAPACITY STEPS					
Step 1	100%	100%	100%	100%	100%
Step 2	50%	50%	50%	67%	67%
Step 3	18%†	25%†	34%†	33%	33%
Step 4	—	—	—	21%†	22%†
MINIMUM FLOW RATES (L/s)					
Evaporator	1.4	1.8	2.7	3.5	4.0
Condenser	1.4	1.8	2.7	3.5	4.0
MAXIMUM FLOW RATES (L/s)					
Evaporator	4.7	6.1	9.3	11.9	13.9
Condenser	4.7	6.1	9.3	11.9	13.9

* 30MPA units (condenserless) are shipped with nitrogen holding charge. Approximate cooler operating charge is shown.
 † With optional hot gas bypass.

NOTES:

- Operating weight includes refrigerant operating charge and weight of fluid in the heat exchangers.
- Manifold option adds approximately 92.1 kg to the operating weight of MPA units and 183.7 kg to the operating weight of MPW units.
- 30MPW units are shipped with full operating charge.

30MPA AIR-COOLED AND 30MPW LIQUID-COOLED UNITS — SI (cont)

UNIT 30MPA,MPW	050	055	060	065	071
NOMINAL kW	177	194	212	229	250
OPERATING WT (kg)					
MPA	634	641	652	666	683
MPA with Manifold	733	740	750	765	782
MPW	727	733	762	777	780
MPW with Manifold	924	931	960	974	978
REFRIGERANT (kg)		R-410A			
MPA*	13.5	14.0	15.0	15.5	17.7
MPW	19.6	20.3	21.6	22.4	22.8
COMPRESSOR		Scroll, Hermetic			
Quantity	2	2	2	2	2
Speed (r/s, 60 Hz/50 Hz)	58/48	58/48	58/48	58/48	58/48
Compressor Nominal kW (A1, A2)	88,88	88,113	88,124	88,141	113,141
Oil Charge (L)	10.5	10.5	10.5	10.5	10.5
Capacity Control — Standard					
No. of Steps	2	2	2	2	2
Minimum Step Capacity (%)	50	44	42	38	44
Capacity Control — Optional Hot Gas Bypass					
No. of Steps	3	3	3	3	3
Minimum Step Capacity (%)	40	35	33	31	38
Capacity Control — Optional Digital Compressor					
No. of Steps	—	—	—	—	—
Minimum Step Capacity (%)	—	—	—	—	—
EVAPORATOR					
Weight (kg, empty)	64.4	64.4	75.2	75.2	85.5
Net Fluid Volume (L)	14.1	14.1	17.0	17.0	19.6
Maximum Refrigerant Pressure (kPa)	4505.7	4505.7	4505.7	4505.7	4505.7
Maximum Fluid-Side Pressure (kPa)	2070.0	2070.0	2070.0	2070.0	2070.0
Water Connections (in.)					
Inlet and Outlet (Victaulic IPS)	2 ¹ / ₂	2 ¹ / ₂	2 ¹ / ₂	2 ¹ / ₂	2 ¹ / ₂
Drain (NPT)	1/2	1/2	1/2	1/2	1/2
Manifold Connections (in.)					
Inlet and Outlet (Victaulic IPS)	6	6	6	6	6
CONDENSER (30MPW Only)					
Weight (kg, empty)	91.8	91.8	109.8	109.8	109.8
Net Fluid Volume (L)	18.9	18.9	22.8	22.8	22.8
Maximum Refrigerant Pressure (kPa)	4505.7	4505.7	4505.7	4505.7	4505.7
Maximum Water-Side Pressure (kPa)	2070.0	2070.0	2070.0	2070.0	2070.0
Water Connections (in.)					
Inlet and Outlet (Victaulic IPS)	2 ¹ / ₂	2 ¹ / ₂	2 ¹ / ₂	2 ¹ / ₂	2 ¹ / ₂
Drain (NPT)	—	—	—	—	—
Manifold Connections (in.)					
Inlet and Outlet (Victaulic IPS)	6	6	6	6	6
CONDENSER REFRIGERANT CONNECTIONS (30MPA Only)					
Liquid Line (ODS) (in.)	1 ¹ / ₈	1 ¹ / ₈	1 ¹ / ₈	1 ¹ / ₈	1 ¹ / ₈
Discharge Line (ODS) (in.)	1 ⁵ / ₈	1 ⁵ / ₈	1 ⁵ / ₈	1 ⁵ / ₈	1 ⁵ / ₈
CHASSIS DIMENSIONS (mm)					
Length	1397	1397	1397	1397	1397
Width	813	813	813	813	813
Height	1685	1685	1685	1685	1685
MINIMUM SYSTEM FLUID VOLUME (L per kW)					
Normal Air Conditioning					
Standard	6.5	6.5	6.5	6.5	6.5
Optional Hot Gas Bypass	4.3	4.3	4.3	4.3	4.3
Optional Digital Compressor	—	—	—	—	—
Low Outdoor Ambient Cooling Operation					
Standard	10.8	10.8	10.8	10.8	10.8
Optional Hot Gas Bypass	10.8	10.8	10.8	10.8	10.8
Optional Digital Compressor	—	—	—	—	—
CAPACITY STEPS					
Step 1	100%	100%	100%	100%	100%
Step 2	50%	44%	42%	38%	44%
Step 3	40%†	35%†	33%†	31%†	38%†
Step 4	—	—	—	—	—
MINIMUM FLOW RATES (L/s)					
Evaporator	4.5	4.9	5.4	5.8	6.7
Condenser	4.5	4.9	5.4	5.8	6.7
MAXIMUM FLOW RATES (L/s)					
Evaporator	15.2	16.8	18.3	19.8	22.7
Condenser	15.2	16.8	18.3	19.8	22.7

* 30MPA units (condenserless) are shipped with nitrogen holding charge. Approximate cooler operating charge is shown.
 † With optional hot gas bypass.

NOTES:

1. Operating weight includes refrigerant operating charge and weight of fluid in the heat exchangers.
2. Manifold option adds approximately 98.9 kg to the operating weight of MPA units and 19.7 kg to the operating weight of MPW units.
3. 30MPW units are shipped with full operating charge.

Options and accessories



ITEM	OPTION*	ACCESSORY†
Hot Gas Bypass	X	X
Digital Scroll Compressor (not available on 30MP015, 050-071 models)	X	
High Condensing (not required on 30MP015-045 models)	X	
High Interrupt	X	
Condenserless	X	
EMM	X	X
Vibration Isolators (Pads)		X
Vibration Isolators (Springs)		X
BACnet Translator		X
LON Translator		X
Non-Fused Disconnect	X	
Sound Enclosure Panels	X	X
Mobility Kit (wheels)	X	X
Medium Temperature Brine	X	
Condenser Water Temperature Sensors		X
Height Adjustment (Leveling) Kit	X	X
Compressor Return Gas Sensor		X
Y Strainer		X
Navigator™ Display Module		X
Remote Enhanced Display		X
Compressor Insulation	X	X
Compressor Sound Blankets	X	
Water Manifold Piping	X	
Water Manifold Victaulic Spacer Fitting Kit		X
BACnet Communication Option	X	

*Factory-installed option.
†Field-installed accessory.

Factory-installed options

Hot gas bypass — Hot gas bypass can be factory-installed to allow additional capacity reduction for unit operation below the minimum step of unloading. This option is not available in combination with medium temperature brine.

Digital scroll compressor — Digital scroll compressors are available as a factory-installed option. These compressors allow for incremental unloading with capacity modulation to better match building load when compared to standard scroll compressors. This option is not available on the 30MP015, 050-071 models.

High interrupt — High interrupt is available as a factory-installed option that gives the chiller a short-circuit current rating of 65 kA (100 kA for 575-v size 015-045 units, 25 kA for 575-v size 050-071 units). A Class J overcurrent protection fuse must be installed ahead of the unit. (The standard interrupt rating is 5 kA.)

Condenserless — Applicable to the 30MPA model only. This option is available for use with remote condensers.

Energy management module (EMM) — The energy management module is used for 4 to 20 mA leaving fluid temperature reset, cooling set point reset, 4 to 20 mA demand limit and two-step demand limit. Temperature reset lets the unit reset the leaving fluid temperature to a higher

temperature during low load conditions. Temperature reset can also be accomplished based on return fluid, outdoor air or space temperature. (The EMM option is not required when using entering-water, outdoor-air, or space temperature for temperature reset. These types of reset are available with the main board. However, an accessory thermistor is required for outdoor-air and/or space temperature reset.) Demand limiting allows the unit capacity to be limited during periods of peak energy usage. Demand limit requires an external 4 to 20 mA signal or a 2-step remote pair of dry contacts. Both the 4 to 20 mA and 2-step demand limit percentage values are adjustable. This is also available as a field-installed accessory.

Non-fused disconnect — For wiring convenience, an electrical power disconnect for line and control power may be factory-installed.

Sound enclosure panels — Units may be ordered with acoustically insulated sheet metal enclosures installed around the unit to reduce radiated sound levels. Panels are also available as a field-installed accessory for all 30MP units.

Medium temperature brine option — Unit must be factory-modified to permit brine operation from 15 to 32 F (–9.4 to 0.0° C) leaving brine temperature. Refrigeration circuit components, such as the expansion device and liquid line solenoid, are modified to permit the low refrigerant flow rates typical of brine duty operation.

Mobility kit — Wheels are shipped with the unit for field installation to aid in transportation of unit to its final installation site. Wheels are rubber type, pivot for easy unit maneuvering, and are lockable for safety. Mobility kit is also available as a separately shipped, field-installed accessory for all 30MP units.

Height adjustment (leveling) kit — A leveling adjustment mechanism is shipped with the unit and must be field-located in each corner of the unit, to facilitate easy installation and connection to existing piping. Leveling kit is also available as a field-installed accessory.

Compressor insulation — Compressor insulation is designed to insulate the scroll compressors and prevent water vapor from condensing on the colder compressor surface.

Compressor sound blankets — Units may be ordered with acoustically insulated sound blankets installed around the compressors to reduce radiated sound levels.

Water manifold piping — Units may be ordered with water manifold piping which allows two or more 30MP chiller modules to be piped together in parallel. Option includes combination valves (balance and isolation).

BACnet communication option — Provides factory installed communication capability with a BACnet MS/TP network. Allows integration with i-Vu® Open control system or a BACnet building automation system.

High Condensing — Units may be ordered with the high condensing option to provide up to 140 F (60.0 C) leaving condenser water temperature, dependent on the cooling load. This option is available on 30MP050-071 models only. (Not required on 30MP015-045 models.)

Field-installed accessories

Hot gas bypass — Hot gas bypass can be field-installed to allow additional capacity reduction for unit operation below the minimum step of unloading. This accessory cannot be used in combination with medium temperature brine.

Vibration isolators — Isolators are installed on the base of the unit to reduce vibration transmission from the unit through the floor. This package consists of 6 resilient pads or 6 springs for each model.

BACnet translator control — Provides an interface between the chiller and a BACnet Local Area Network (LAN, i.e., MS/TP EIA-485).

LON (local operating network) Translator Control — Provides an interface between the unit and a local operating network (i.e., LonWorks* FT-10A ANSI/EIA-709.1).

Condenser water temperature sensors — This accessory allows measurement of condenser water entry and leaving temperatures.

Sound enclosure panels — This accessory is an acoustically insulated sheet metal enclosure installed around the unit to reduce radiated sound levels. Panels are also available as a factory-installed option for all 30MP units.

Energy management module (EMM) — The energy management module is used for 4 to 20 mA leaving fluid temperature reset, cooling set point reset, 4 to 20 mA demand limit and two-step demand limit. Temperature reset lets the unit reset the leaving fluid temperature to a higher temperature during low load conditions. Temperature reset can also be accomplished based on return fluid, outdoor air or space temperature. (The EMM accessory is not required when using entering-water, outdoor-air, or space temperature for temperature reset. These types of reset are available with the main board. However, an accessory thermistor is required for outdoor air and/or space temperature reset.) Demand limiting allows the unit capacity to be limited during periods of peak energy usage. Demand limit requires an external 4 to 20 mA signal or a 2-step remote pair of dry contacts. Both the 4 to 20 mA and 2-step demand limit percentage values are adjustable. This is also available as a factory-installed option.

Mobility kit — Wheels may be field-installed on the unit to aid in transportation of unit to its final installation site. Wheels are rubber type, pivot for easy unit maneuvering, and are lockable for safety.

Height adjustment (leveling) kit — Leveling adjustment mechanism located in each corner of the unit, to facilitate easy installation and connection to existing piping. Leveling kit is also available as a factory-installed option for all 30MP units.

Navigator™ display module — The accessory provides a portable, hand held display module for convenient access to unit status, operation, configuration and troubleshooting diagnostics capability. The 4-line, 80-character LCD (liquid crystal display) display provides clear language information in English, French, Spanish or Portuguese. The weatherproof enclosure and industrial grade extension cord make the Navigator module ideally suited for outdoor applications. Magnets located on the back of the module allow attachment to any sheet metal component for hands-free operation.

Remote enhanced display — The accessory kit contains a remotely mounted 40-character per line, 16-line display panel for unit diagnostics.

Y strainer — A strainer with a minimum of 40 mesh must be installed within 10 ft (3 m) of the heat exchanger fluid inlet to prevent debris from clogging or damaging the heat exchanger. This strainer is required and is available as an accessory. The strainer is available in sizes from 1.5 to 6 inches.

Compressor return gas sensor — Sensor is available as an accessory for field installation to measure compressor return gas temperature. (Standard on 30MP050-071 models.)

Compressor insulation — Compressor insulation is available as an accessory for field installation to insulate the scroll compressors and prevent water vapor from condensing on the colder compressor surface.

Water manifold Victaulic spacer fitting kit — The kit consists of Victaulic fittings and spacer pipe to allow for easy installation of water manifold units.

*Registered trademark of Echelon Corporation.

30MPA015-045 (AIR-COOLED CHILLERS)

UNIT	OPERATING WEIGHT (lb) STANDARD UNIT	DIMENSIONS (in.)						NUMBER OF COMPRESSORS
		A	B	C	D	E	F	
30MPA015	626 (284 kg)	17.80 (452 mm)	25.10 (638 mm)	31.49 (800 mm)	5.54 (141 mm)	6.44 (164 mm)	18.50 (470 mm)	2
30MPA020	635 (288 kg)	17.60 (447 mm)	25.20 (640 mm)	31.39 (797 mm)	5.87 (149 mm)	11.12 (282 mm)	17.95 (456 mm)	
30MPA030	722 (327 kg)	17.00 (432 mm)	26.00 (660 mm)	30.69 (780 mm)	5.99 (152 mm)	11.00 (279 mm)	17.72 (450 mm)	
30MPA040	913 (414 kg)	17.50 (445 mm)	25.90 (658 mm)	33.50 (851 mm)	5.99 (152 mm)	11.00 (279 mm)	17.72 (450 mm)	3
30MPA045	934 (424 kg)	17.40 (442 mm)	26.00 (660 mm)	33.49 (851 mm)	5.99 (152 mm)	11.00 (279 mm)	17.72 (450 mm)	

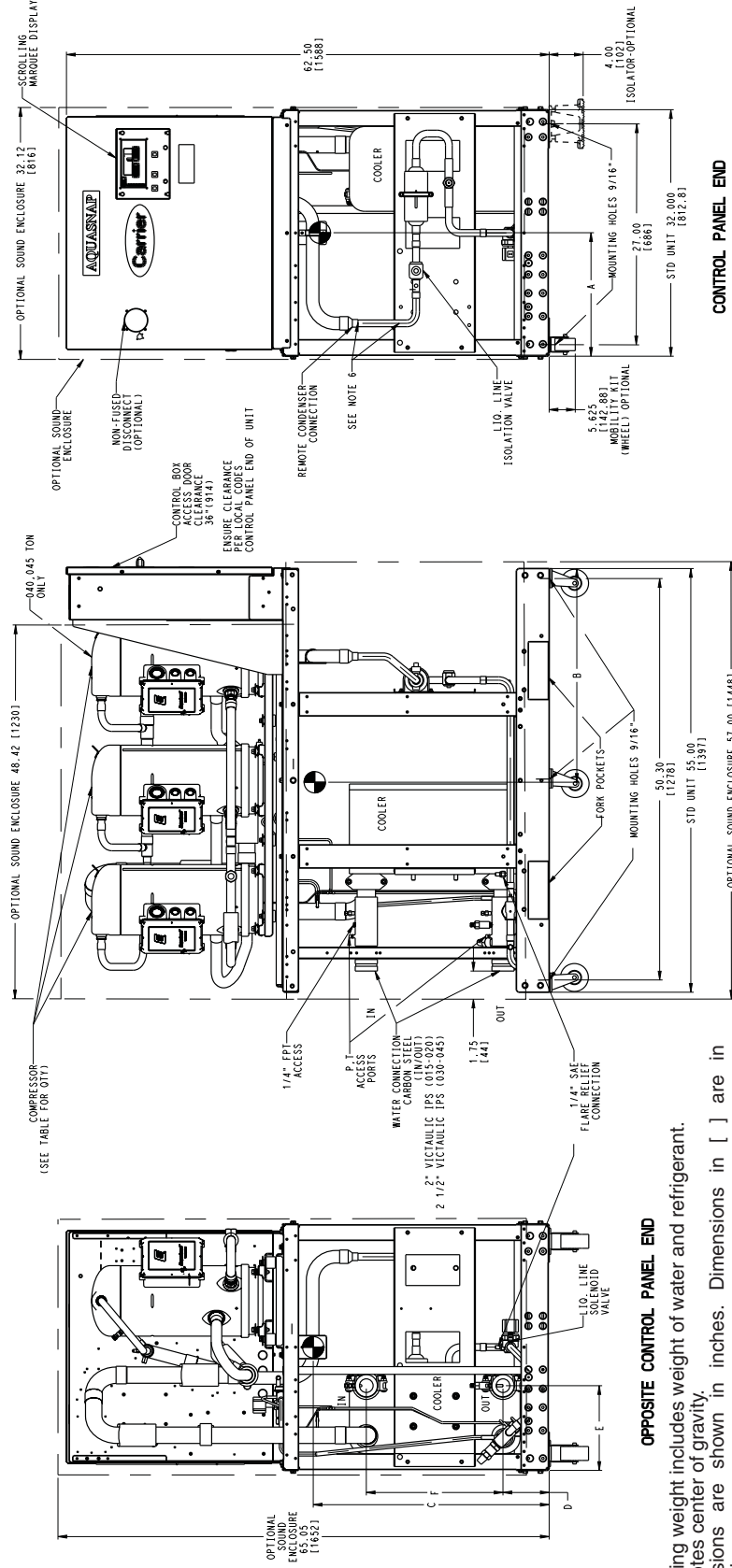
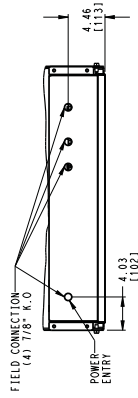

- NOTES:**
- Operating weight includes weight of water and refrigerant.
 - Denotes center of gravity.
 - Dimensions are shown in inches. Dimensions in [] are in millimeters.
 - Allow 36-in. (914 mm) clearance on control panel end, opposite control panel end and above the unit. All clearances must be in accordance with local codes.
 - Denotes accessory or factory-installed option.
 - Unit shipped with nitrogen holding charge. Field removal of tube and reducing coupling is required. Consult Installation Instructions for discharge and liquid pipe connection sizes.

30MPA050-071 (AIR-COOLED CHILLERS)

UNIT	OPERATING WEIGHT (lb) STANDARD UNIT	DIMENSIONS (in.)					NUMBER OF COMPRESSORS
		A	B	C	D	E	
30MPA050	1398 (634 kg)	14.10 (358.1 mm)	27.38 (695.4 mm)	37.56 (954.0 mm)			
30MPA055	1413 (641 kg)	14.06 (357.1 mm)	27.39 (695.7 mm)	37.62 (955.5 mm)			
30MPA060	1437 (652 kg)	14.26 (362.2 mm)	27.37 (695.2 mm)	37.36 (948.9 mm)	6.43 (163.4 mm)	8.45 (214.6)	2 (20.43 (519.0))
30MPA065	1468 (666 kg)	14.17 (359.9 mm)	27.39 (695.7 mm)	37.48 (952.0 mm)			
30MPA071	1506 (683 kg)	14.31 (363.4 mm)	27.30 (693.4 mm)	38.08 (967.2 mm)			

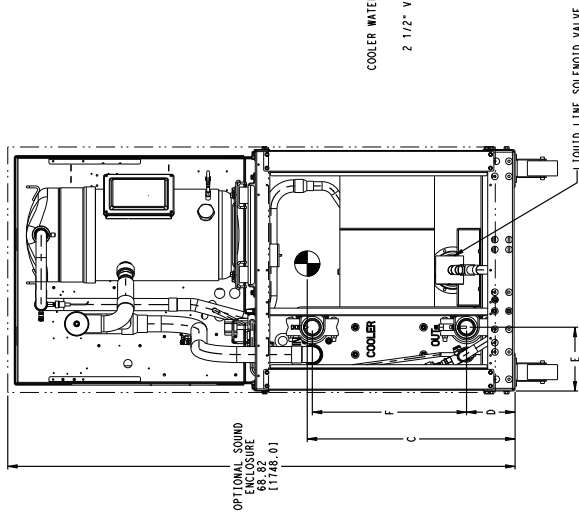
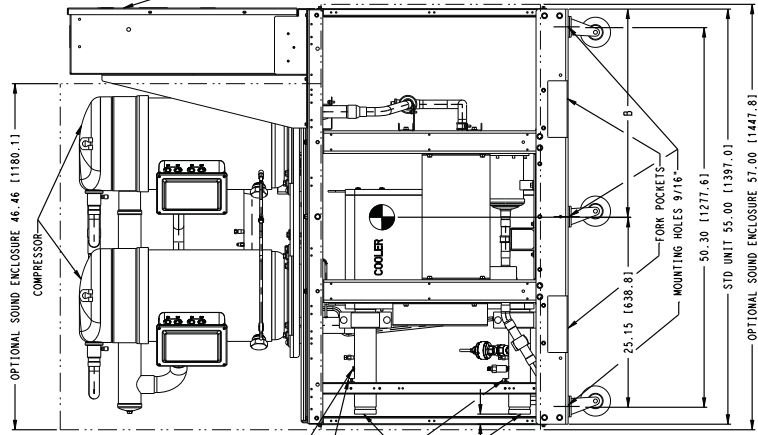
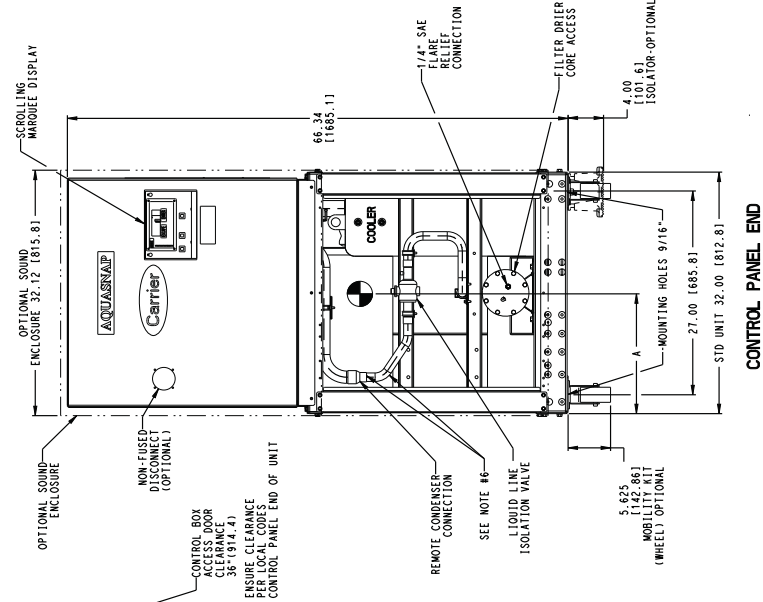
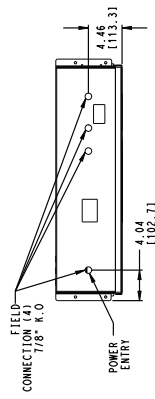

OPPOSITE CONTROL PANEL END

- NOTES:
- Operating weight includes weight of water and refrigerant.
 - Denotes center of gravity.
 - Dimensions are shown in inches. Dimensions in [] are in millimeters.
 - Allow 36-in. (914 mm) clearance on control panel end, opposite control panel end and above the unit. All clearances must be in accordance with local codes.
 - Denotes accessory or factory-installed option.
 - Unit shipped with nitrogen holding charge. Field removal of tube and reducing coupling is required. Consult Installation Instructions for discharge and liquid pipe connection sizes.

Dimensions (cont)

30MPA015-045 (AIR-COOLED CHILLERS) MANIFOLD UNIT

UNIT	OPERATING WEIGHT (lb) MANIFOLD UNIT	DIMENSIONS (in.)						NUMBER OF COMPRESSORS
		A	B	C	D	E	F	
30MPA015	829 (377 kg)	17.40 (442 mm)	30.80 (782 mm)	27.20 (691 mm)	5.54 (141 mm)	6.44 (164 mm)	18.50 (470 mm)	2
30MPA020	838 (381 kg)	17.20 (437 mm)	30.80 (782 mm)	27.10 (688 mm)	5.87 (149 mm)	11.12 (282 mm)	17.95 (456 mm)	
30MPA030	925 (421 kg)	16.80 (427 mm)	30.90 (785 mm)	27.00 (686 mm)	5.99 (152 mm)	11.00 (279 mm)	17.72 (450 mm)	3
30MPA040	1116 (507 kg)	17.30 (439 mm)	30.00 (762 mm)	30.00 (762 mm)	5.99 (152 mm)	11.00 (279 mm)	17.72 (450 mm)	
30MPA045	1137 (517 kg)	17.20 (437 mm)	30.00 (762 mm)	30.00 (762 mm)	5.99 (152 mm)	11.00 (279 mm)	17.72 (450 mm)	

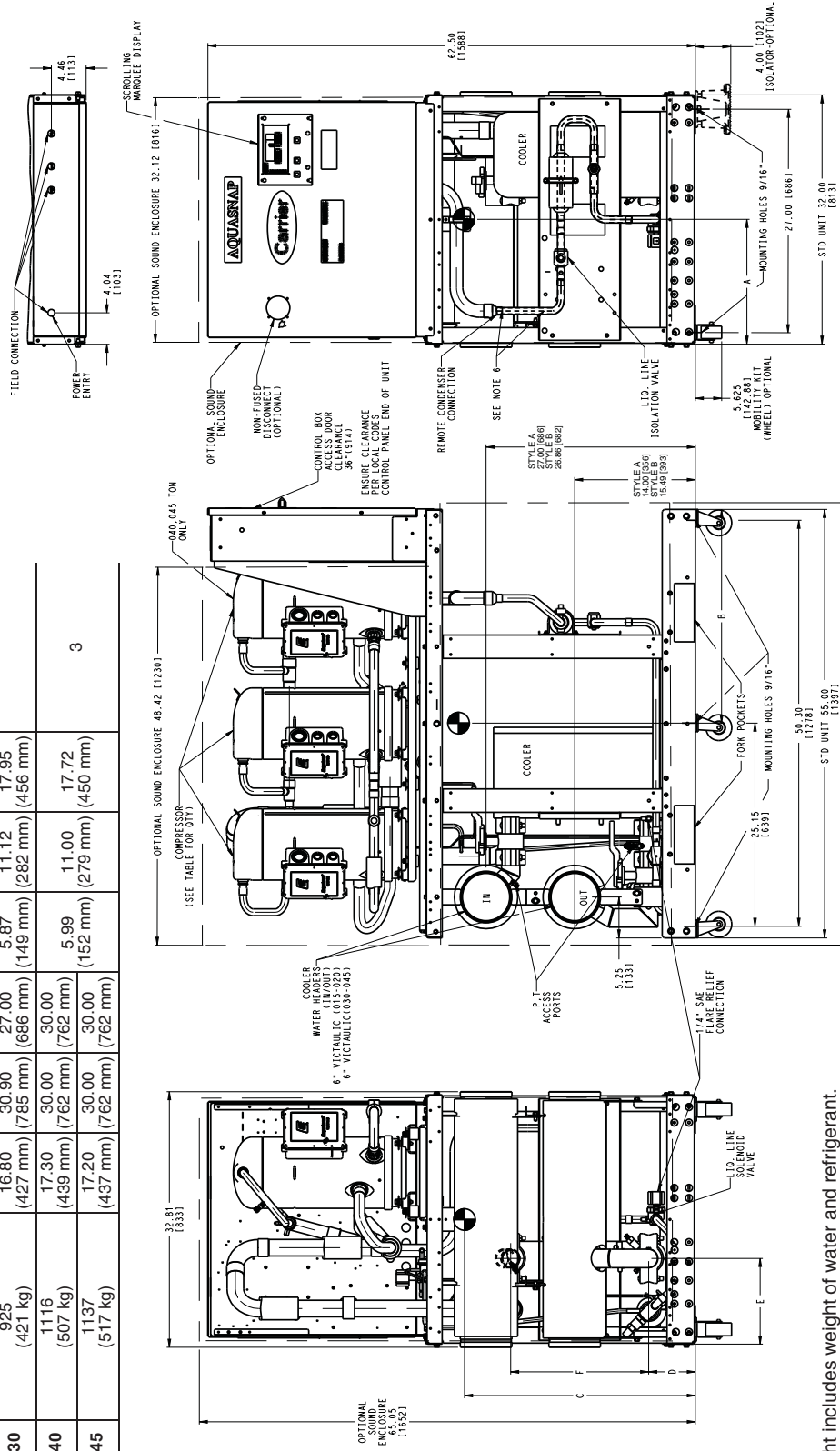

NOTES:

- Operating weight includes weight of water and refrigerant.
- Denotes center of gravity.
- Dimensions are shown in inches. Dimensions in [] are in millimeters.
- Allow 36-in. (914 mm) clearance on control panel end, opposite control panel end and above the unit. All clearances must be in accordance with local codes.
- Denotes accessory or factory-installed option.
- Unit shipped with nitrogen holding charge. Field removal of tube and reducing coupling is required. Consult installation instructions for discharge and liquid pipe connection sizes.

30MPA050-071 (AIR-COOLED CHILLERS) MANIFOLD UNIT

UNIT	OPERATING WEIGHT (lb) MANIFOLD UNIT	DIMENSIONS (in.)					NUMBER OF COMPRESSORS
		A	B	C	D	E	
30MPA050	1616 (733 kg)	14.36 (364.7 mm)	30.21 (767.3 mm)	34.36 (872.7 mm)			
30MPA055	1631 (740 kg)	14.32 (363.7 mm)	30.19 (766.8 mm)	34.44 (874.8 mm)			
30MPA060	1655 (750 kg)	14.49 (368.0 mm)	30.14 (765.5 mm)	34.26 (870.2 mm)	6.43 (163.4 mm)	8.45 (214.6 mm)	20.43 (519.0 mm)
30MPA065	1686 (765 kg)	14.41 (366.0 mm)	30.10 (764.5 mm)	34.42 (874.2 mm)			
30MPA071	1724 (782 kg)	14.52 (368.8 mm)	29.96 (760.9 mm)	35.01 (889.2 mm)			

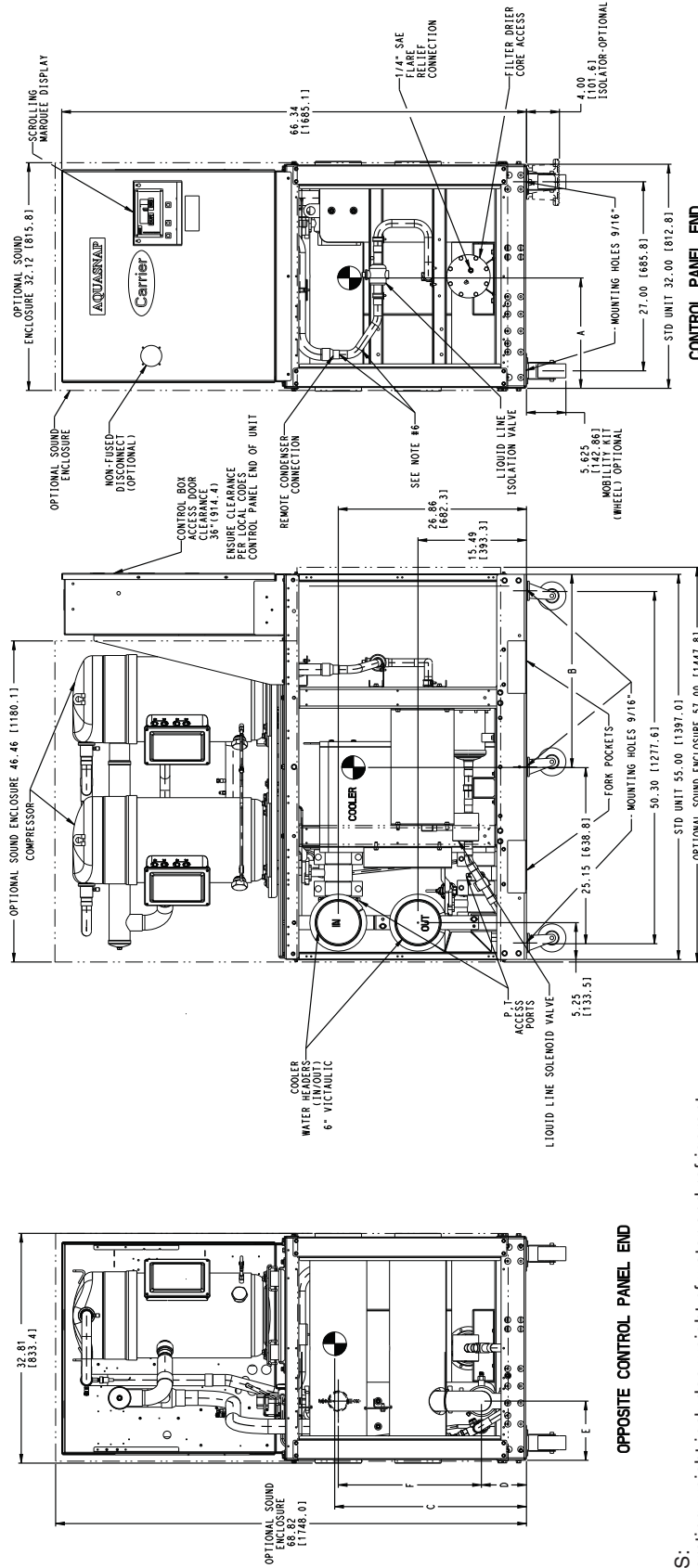
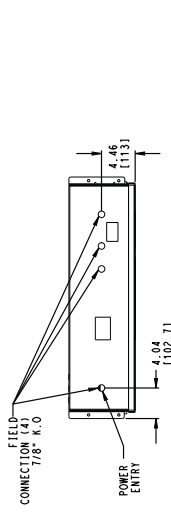

- NOTES:**
- Operating weight includes weight of water and refrigerant.
 - ☉ Denotes center of gravity.
 - Dimensions are shown in inches. Dimensions in [] are in millimeters.
 - Allow 36-in. (914 mm) clearance on control panel end, opposite control panel end and above the unit. All clearances must be in accordance with local codes.
 - Denotes accessory or factory-installed option.
 - Unit shipped with nitrogen holding charge. Field removal of tube and reducing coupling is required. Consult Installation Instructions for discharge and liquid pipe connection sizes.

Dimensions (cont)

30MPW015-045 (LIQUID-COOLED CHILLERS)

UNIT	OPERATING WEIGHT (lb) STANDARD UNIT	DIMENSIONS (in.)										NUMBER OF COMPRESSORS
		A	B	C	D	E	F	G	H	J		
30MPW015	680 (308 kg)	18.50 (470 mm)	24.80 (630 mm)	30.53 (775 mm)	5.54 (141 mm)	6.44 (164 mm)	18.50 (470 mm)	5.54 (141 mm)	6.44 (164 mm)	18.50 (470 mm)	18.50 (470 mm)	2
30MPW020	704 (319 kg)	18.20 (462 mm)	25.20 (640 mm)	28.61 (727 mm)	5.87 (149 mm)	11.12 (282 mm)	16.89 (429 mm)	5.87 (149 mm)	11.12 (282 mm)	17.95 (456 mm)	17.95 (456 mm)	2
30MPW030	862 (391 kg)	18.60 (472 mm)	25.10 (638 mm)	30.96 (786 mm)	5.87 (149 mm)	11.12 (282 mm)	17.95 (456 mm)	5.99 (152 mm)	11.00 (279 mm)	17.72 (450 mm)	17.72 (450 mm)	3
30MPW040	1099 (499 kg)	18.90 (480 mm)	24.90 (632 mm)	30.22 (768 mm)								3
30MPW045	1190 (540 kg)											3

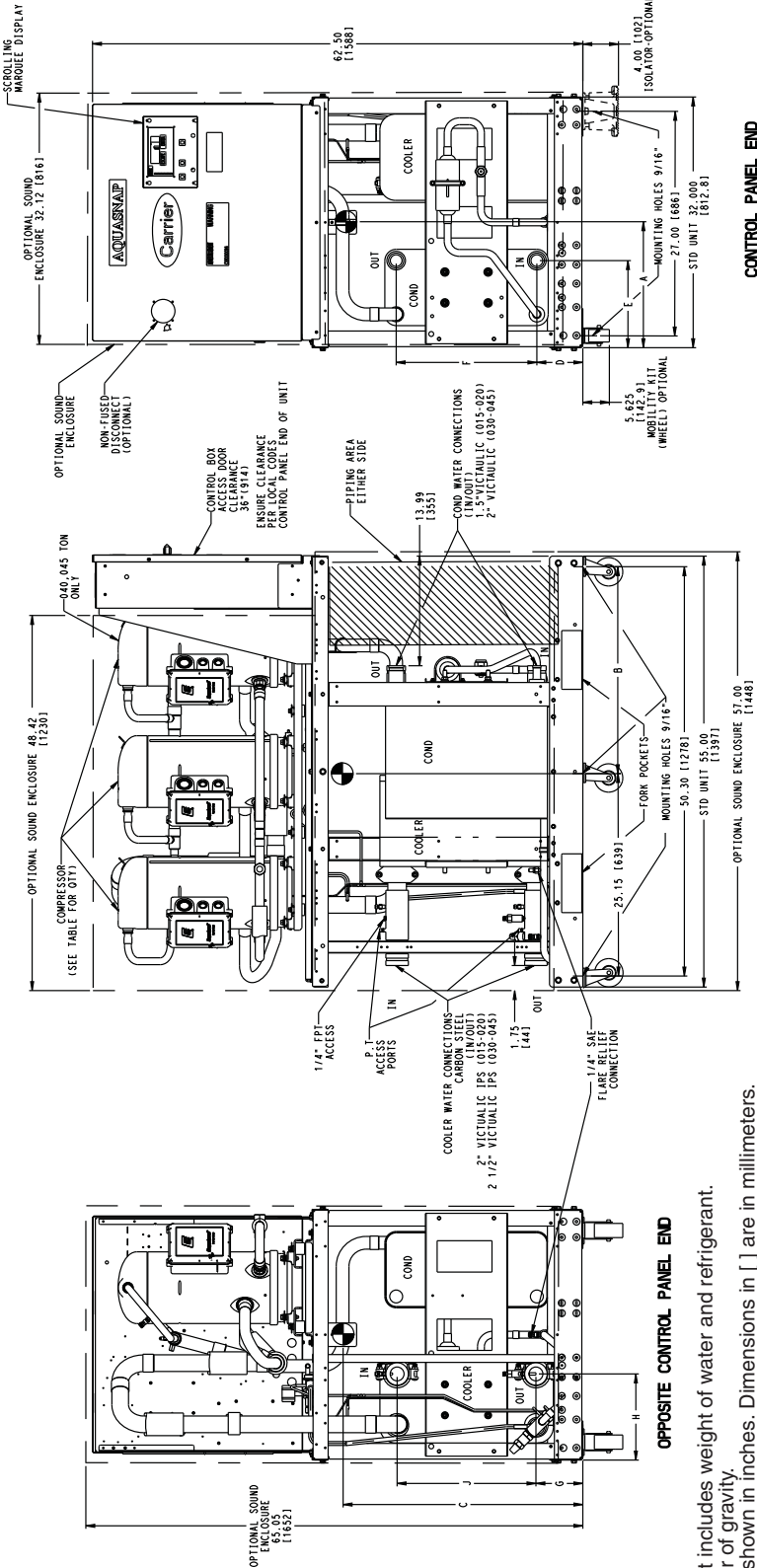
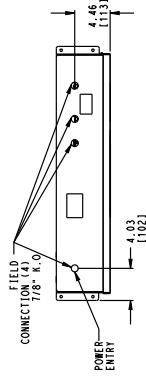

OPPOSITE CONTROL PANEL END

- NOTES:**
- Operating weight includes weight of water and refrigerant.
 - Denotes center of gravity.
 - Dimensions are shown in inches. Dimensions in [] are in millimeters.
 - Allow 36-in. (914 mm) clearance on control panel end, opposite control panel end and above the unit. All clearances must be in accordance with local codes.
 - Denotes accessory or factory-installed option.
 - Unit shipped with nitrogen holding charge. Field removal of tube and reducing coupling is required. Consult Installation Instructions for discharge and liquid pipe connection sizes.

30MPW050-071 (LIQUID-COOLED CHILLERS)

UNIT	OPERATING WEIGHT (lb) STANDARD UNIT	DIMENSIONS (in.)										NUMBER OF COMPRESSORS	
		A	B	C	D	E	F	G	H	J			
30MPW050	1602 (727 kg)	12.65 (321.3 mm)	27.33 (694.2 mm)	35.58 (903.7 mm)									
30MPW055	1617 (733 kg)	12.61 (320.3 mm)	27.34 (694.4 mm)	35.65 (905.5 mm)									
30MPW060	1681 (762 kg)	12.65 (321.3)	27.76 (705.1 mm)	35.13 (892.3 mm)	6.43 (163.4 mm)	20.43 (519.0)	6.43 (163.4 mm)	8.45 (214.6)	20.43 (519.0)	8.45 (214.6)	20.43 (519.0)	2	
30MPW065	1712 (777 kg)	12.58 (319.5)	27.76 (705.1 mm)	35.27 (895.5 mm)									
30MPW071	1719 (780 kg)	12.79 (324.9)	27.67 (702.9 mm)	35.02 (889.5 mm)									

NOTES:

- Operating weight includes weight of water and refrigerant.
- Denotes center of gravity.
- Dimensions are shown in inches. Dimensions in [] are in millimeters.
- Allow 36-in. (914 mm) clearance on control panel end, opposite control panel end and above the unit. All clearances must be in accordance with local codes.
- Denotes accessory or factory-installed option.
- Unit shipped with nitrogen holding charge. Field removal of tube and reducing coupling is required. Consult Installation Instructions for discharge and liquid pipe connection sizes.

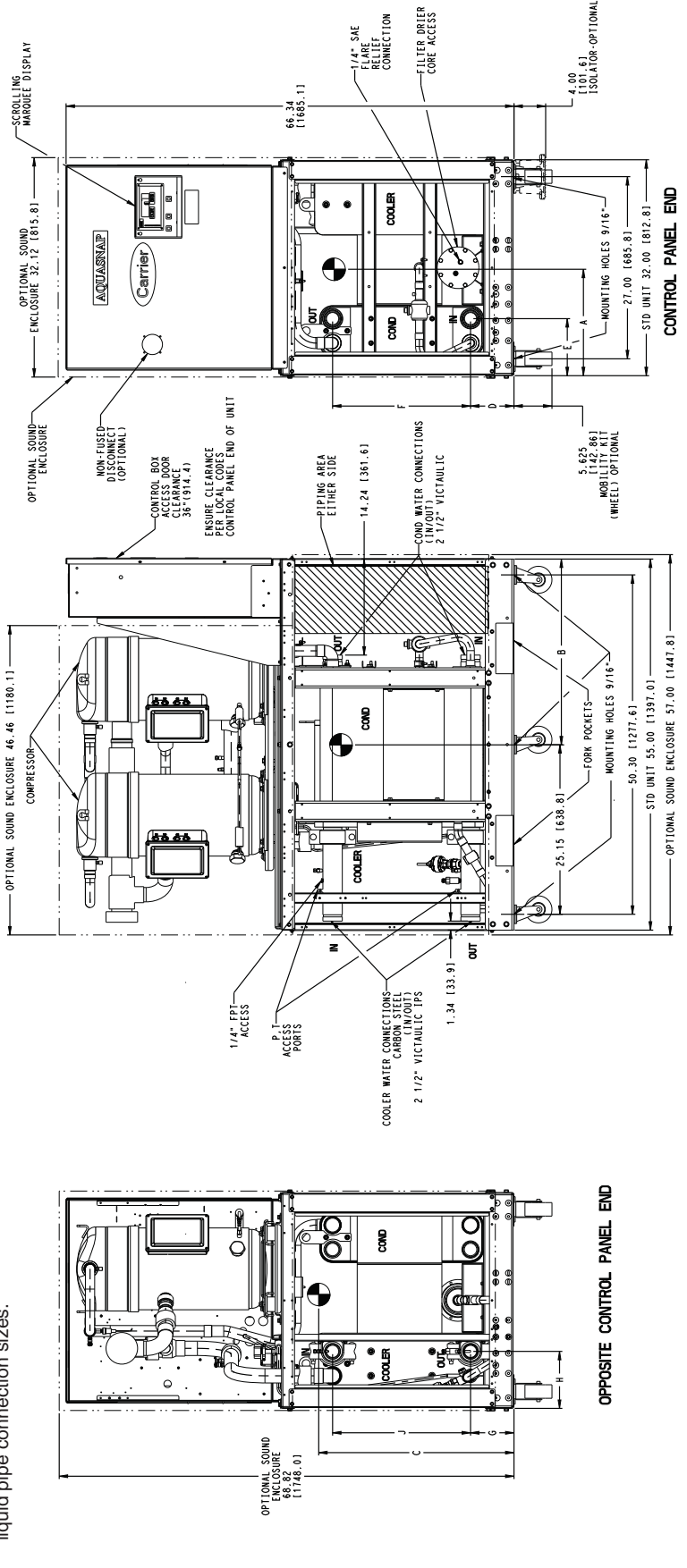
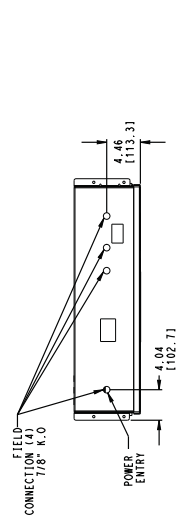

Dimensions (cont)

30MPW015-045 (LIQUID-COOLED CHILLERS) MANIFOLD UNIT

UNIT	OPERATING WEIGHT (lb)	DIMENSIONS (in.)										NUMBER OF COMPRESSORS
		A	B	C	D	E	F	G	H	J		
30MPW015	1085 (493 kg)	17.50 (445 mm)	25.70 (653 mm)	25.10 (638 mm)	5.54 (141 mm)	6.44 (164 mm)	18.50 (470 mm)	5.54 (141 mm)	6.44 (164 mm)	18.50 (470 mm)		2
30MPW020	1109 (504 kg)	17.50 (445 mm)	25.60 (650 mm)	25.00 (635 mm)								
30MPW030	1267 (576 kg)	17.50 (445 mm)	25.80 (655 mm)	24.60 (625 mm)		16.89 (429 mm)	5.87 (149 mm)	11.12 (282 mm)	17.95 (456 mm)			3
30MPW040	1504 (684 kg)	17.90 (455 mm)	25.60 (650 mm)	27.00 (686 mm)	5.87 (149 mm)	11.12 (282 mm)	17.95 (456 mm)	5.99 (152 mm)	11.00 (279 mm)	17.72 (450 mm)		
30MPW045	1595 (725 kg)	18.10 (460 mm)	25.50 (648 mm)	26.60 (676 mm)								

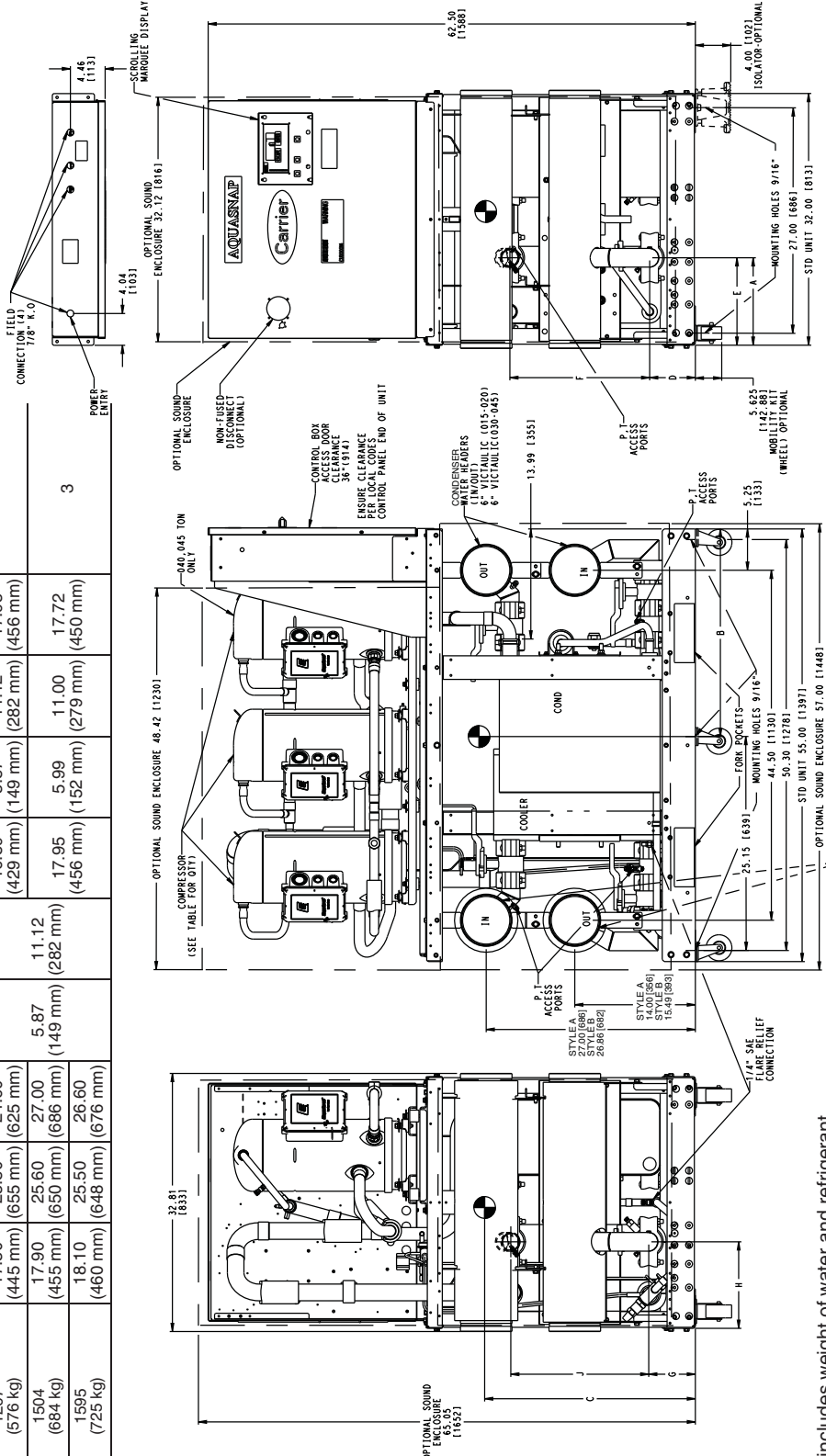

- NOTES:**
1. Operating weight includes weight of water and refrigerant.
 2. Ⓞ Denotes center of gravity.
 3. Dimensions are shown in inches. Dimensions in [] are in millimeters.
 4. Allow 36-in. (914 mm) clearance on control panel end, opposite control panel end and above the unit. All clearances must be in accordance with local codes.
 5. ----- Denotes accessory or factory-installed option.
 6. Unit shipped with nitrogen holding charge. Field removal of tube and reducing coupling is required. Consult installation instructions for discharge and liquid pipe connection sizes.

30MPW050-071 (LIQUID-COOLED CHILLERS) MANIFOLD UNIT

UNIT	OPERATING WEIGHT (lb) MANIFOLD UNIT	DIMENSIONS (in.)										NUMBER OF COMPRESSORS				
		A	B	C	D	E	F	G	H	J						
30MPW050	2038 (924.4 kg)	13.34 (338.8 mm)	27.28 (692.9 mm)	31.39 (797.3 mm)												
30MPW055	2053 (931.2 kg)	13.31 (338.1 mm)	27.29 (693.2 mm)	31.48 (799.6 mm)												
30MPW060	2117 (960.2 kg)	13.32 (338.3 mm)	27.62 (701.5 mm)	31.19 (792.2 mm)	6.43 (163.4 mm)	8.45 (214.6 mm)	20.43 (519.0 mm)	6.43 (163.4 mm)	8.45 (214.6 mm)						20.43 (519.0 mm)	2
30MPW065	2148 (974.3 kg)	13.26 (336.8 mm)	27.63 (701.8 mm)	31.36 (796.5 mm)												
30MPW071	2155 (977.5 kg)	13.42 (340.8 mm)	27.55 (699.8 mm)	31.17 (791.7 mm)												

NOTES:

- Operating weight includes weight of water and refrigerant.
- Denotes center of gravity.
- Dimensions are shown in inches. Dimensions in [] are in millimeters.
- Allow 36-in. (914 mm) clearance on control panel end, opposite control panel end and above the unit. All clearances must be in accordance with local codes.
- Denotes accessory or factory-installed option.
- Unit shipped with nitrogen holding charge. Field removal of tube and reducing coupling is required. Consult installation instructions for discharge and liquid pipe connection sizes.

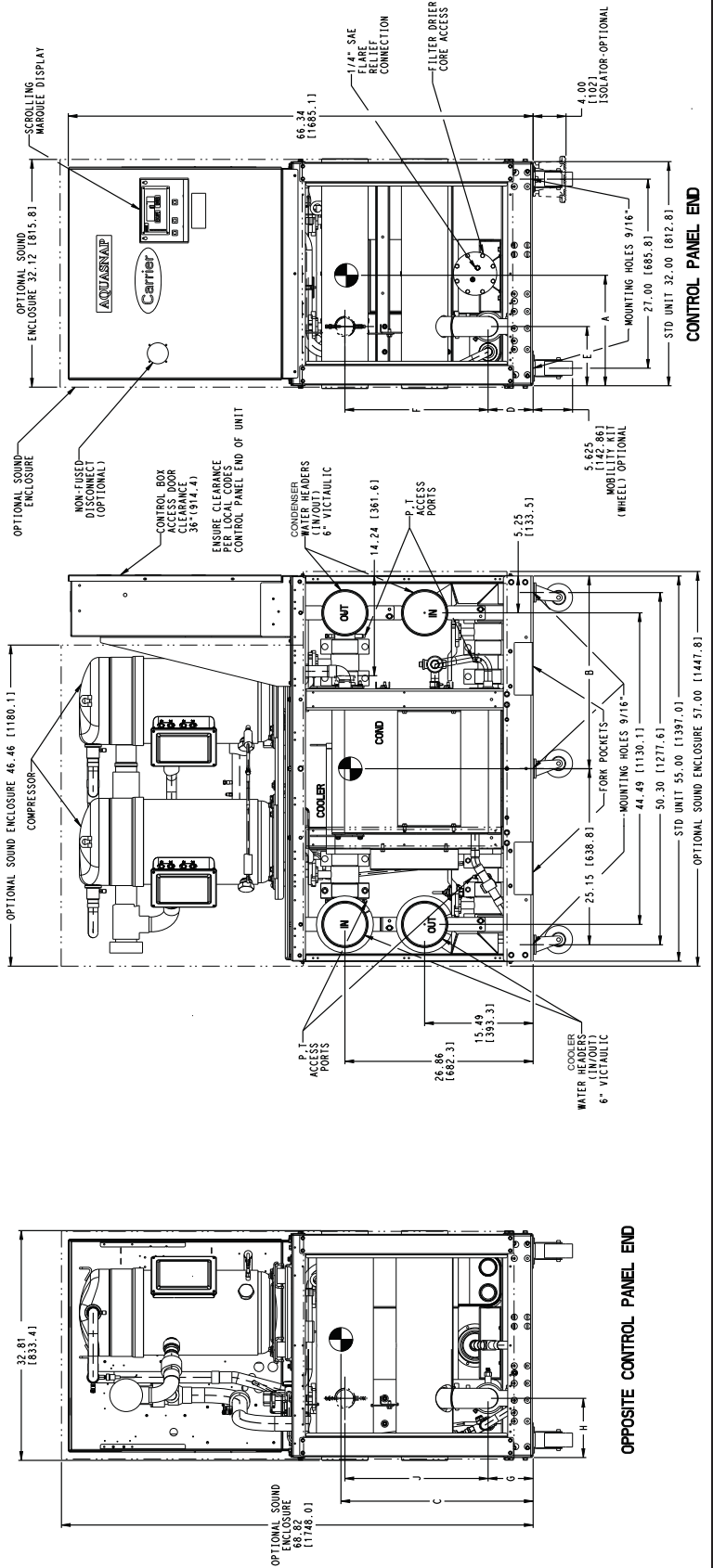
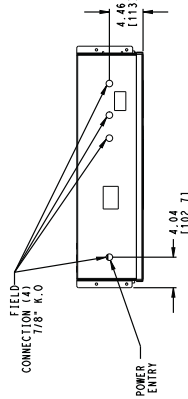

Dimensions (cont)

30MP CHILLER UNITS MANIFOLDED TOGETHER* — NO SPACER PIPE (30MP045 UNITS SHOWN)

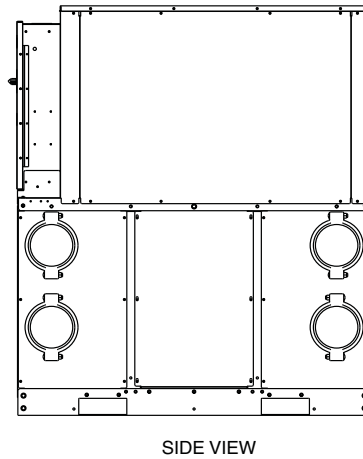
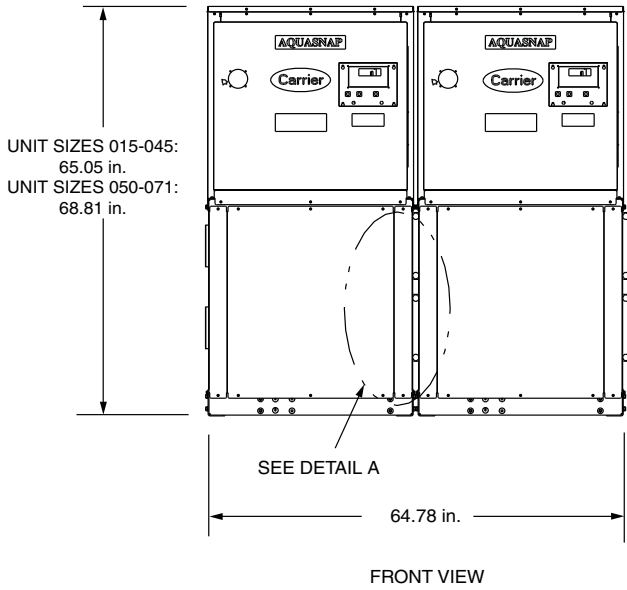
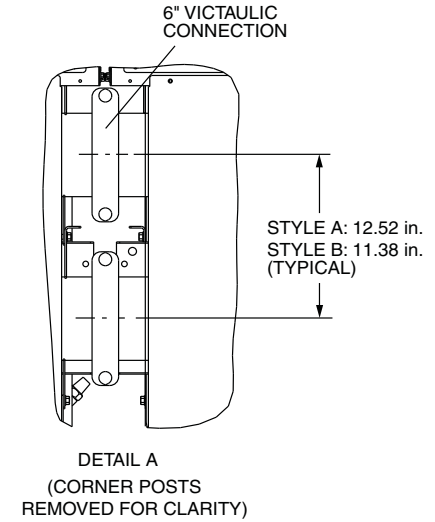
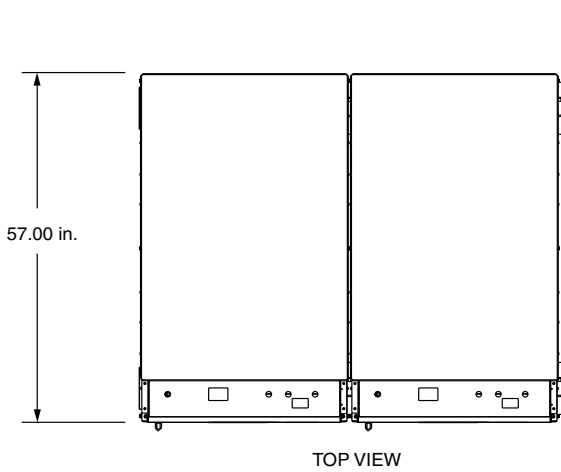

*Style A water manifold is not compatible with Style B. Style A water manifold is used on 30MP015-045 units made before November 2015. Style B water manifold is used on 30MP050-071 units and 30MP015-045 units made starting November 2015. See current Installation Manual for details.

**30MP CHILLER UNITS MANIFOLDED TOGETHER* — WITH SPACER PIPE
(30MP045 UNITS SHOWN)**

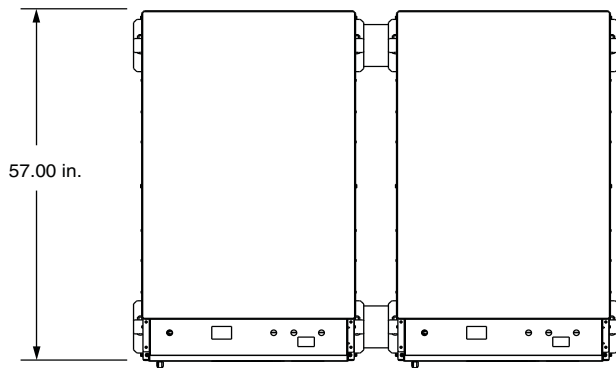

TOP VIEW

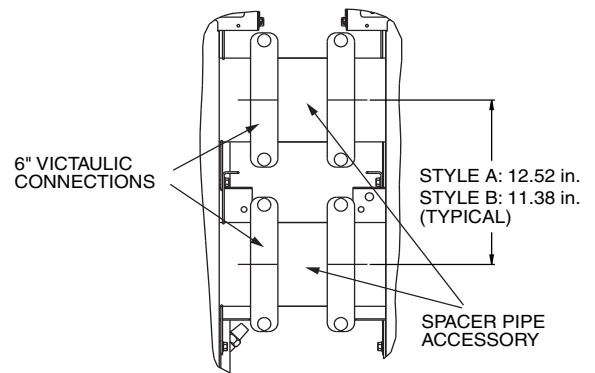

DETAIL A

(CORNER POSTS
REMOVED FOR CLARITY)

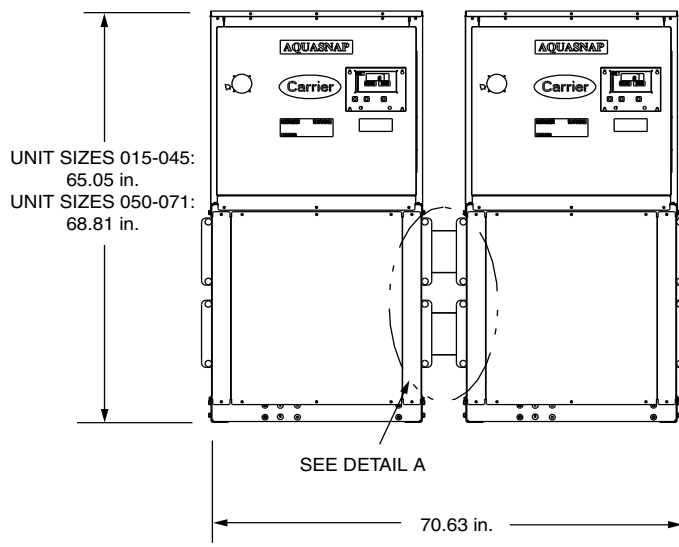

FRONT VIEW

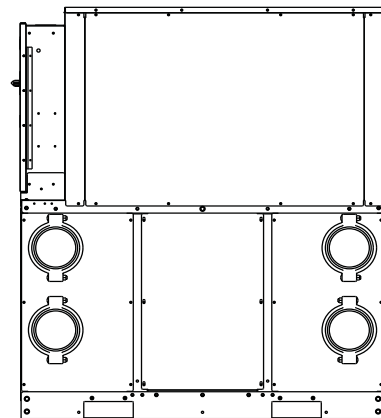

SIDE VIEW

*Style A water manifold is not compatible with Style B. Style A water manifold is used on 30MP015-045 units made before November 2015. Style B water manifold is used on 30MP050-071 units and 30MP015-045 units made starting November 2015. See current Installation Manual for details.

Application data



Unit storage

To protect the unit, store machine and starter indoors, protected from construction dirt and moisture. Inspect under shipping tarps, bags, or crates to be sure water has not collected during transit. Keep protective shipping covers in place until machine is ready for installation.

Unit location

Unit should be level (particularly in its major lengthwise dimension) to ensure proper oil return. It should be determined prior to installation if any special treatment is required to ensure a level installation.

The unit should be located indoors in an area where the temperature is between 50 and 104 F (10 and 40 C).

Evaporator fluid temperature

1. *Maximum* sustained leaving chilled-fluid temperature (LCWT) is 60 F (16 C). For sustained operation, entering-fluid temperature should not exceed 75 F (23.9 C). Unit can start and pull down with up to 95 F (35 C) entering-fluid temperature due to the pressure limiting feature of the expansion valve.
2. *Minimum* LCWT for standard units is 32 F (0° C). For temperatures above 32 F (0° C) and below 40 F (4 C), ensure the chilled water loop has a suitable brine solution. For applications with LCWT below 32 F (0° C) the medium temperature brine option must be selected. Refer to Medium Temperature Brine Option section below.

Medium temperature brine option (required for LCWT 15 to 32 F [-9.4 to 0.0° C])

For all applications with LCWT below 40 F (4 C), a suitable brine (or antifreeze and water solution) must be provided to ensure freeze protection. The solution crystallization point of the brine should be below the suction temperature of the evaporator, and at least 15° F (8.3° C) below the leaving brine temperature. The brine solution must also be properly inhibited to provide suitable corrosion protection. For applications with LCWT below 32 F (0° C), the 30MP unit requires factory modification and the medium brine temperature option must be selected.

Condenser water temperature

1. 30MPW015-045, 30MPW050-071 High Condensing: *Maximum* leaving condenser-water temperature is 140 F (60 C). This temperature is not available for brine units.
2. 30MPW050-071 Standard: *Maximum* leaving condenser-water temperature is 120 F (49 C). This temperature is not available for brine units.
3. 30MPW015-045, 30MPW050-071 High Condensing: *Minimum* entering condenser-water temperature without condenser flow regulation is 65 F (18 C).
4. 30MPW050-071 Standard: *Minimum* entering condenser-water temperature without condenser flow regulation is 65 F (18 C).

Evaporator and liquid-cooled condenser flow range

Ratings and performance data in this publication are for a cooling temperature rise of 10° F (5.6° C) and are suitable for a range from 5° to 15° F (2.7° to 8.3° C) temperature rise without adjustment. Units may be operated at a different temperature range, provided flow limits are not exceeded and corrections to capacity, etc. are made. For minimum flow rates, see Minimum Evaporator and Condenser Flow Rates and Minimum Fluid Volume in Circulation tables on page 23. High flow rate is limited by pressure drop that can be tolerated.

Minimum evaporator flow — The minimum evaporator flow (maximum evaporator temperature rise) for standard units is shown in Minimum Evaporator and Condenser Flow Rates and Minimum Fluid Volume in Circulation tables on page 23. When gpm (L/s) required is lower (or rise is higher), follow these recommendations:

- a. Multiple smaller chillers may be applied in series, each providing a portion of the design temperature rise.
- b. Chilled fluid may be recirculated to raise flow rate. However, the mixed temperature entering evaporator must be maintained at a minimum of at least 5° F (2.8° C) above the leaving chilled fluid temperature.

NOTE: Recirculation flow is shown below.

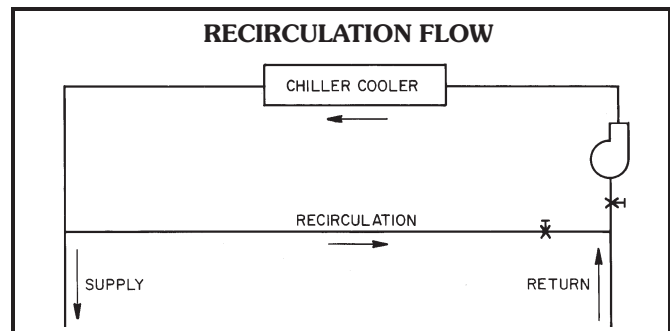

Maximum evaporator flow (5 gpm/ton or < 5° F rise [0.09 L/s · kW or < 2.7° C rise]) — The maximum evaporator flow results in practical maximum pressure drop through evaporator.

The return fluid may bypass the evaporator to keep pressure drop through the evaporator within acceptable limits. This permits a higher ΔT with lower fluid flow through evaporator and mixing after evaporator.

Bypass flow is shown below.

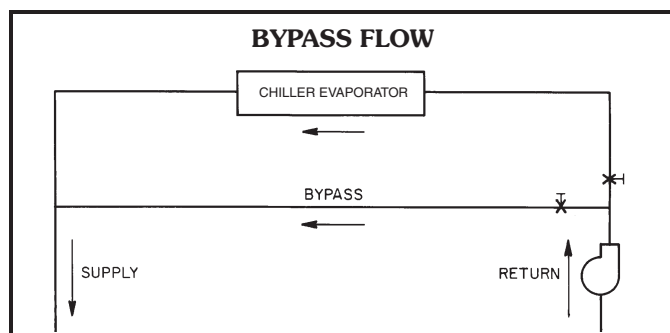

Variable evaporator flow rates — These variable rates may be applied to standard chillers. However, the unit will attempt to maintain a constant leaving chilled-fluid temperature. In such cases, minimum fluid loop volume must be in excess of 3 gallons per ton (3.2 L per kW), and flow rate must change in steps of less than 10% per minute. Apply 6 gal. per ton (6.5 L per kW) fluid loop volume minimum if flow rate changes more rapidly.

Minimum liquid-cooled condenser flow — This value (maximum rise) is shown in Minimum Evaporator and Condenser Flow Rates and Minimum Fluid Volume in Circulation tables below. Condensers may be piped in series. Ensure leaving-water temperature does not exceed the maximum allowed as listed in Condenser Water Temperature on page 22.

Chilled fluid loop volume — For temperature stability and accuracy, the minimum fluid loop volume in circulation must equal or exceed the values listed in the Minimum Evaporator and Condenser Flow Rates and Minimum Fluid Volume in Circulation tables below.

MINIMUM EVAPORATOR AND CONDENSER FLOW RATES

UNIT SIZE	EVAPORATOR		CONDENSER	
	Gal./Min	L/s	Gal./Min	L/s
30MP015	22	1.4	22	1.4
30MP020	28	1.8	28	1.8
30MP030	43	2.7	43	2.7
30MP040	55	3.5	55	3.5
30MP045	64	4.0	64	4.0
30MP050	70	4.5	70	4.5
30MP055	77	4.9	77	4.9
30MP060	84	5.4	84	5.4
30MP065	91	5.8	91	5.8
30MP071	104	6.7	104	6.7

MINIMUM FLUID VOLUME IN CIRCULATION

30MP UNIT SIZE	NORMAL AIR CONDITIONING APPLICATION gal/ton (L per kW)			PROCESS COOLING OR LOW AMBIENT OPERATION APPLICATION gal/ton (L per kW)		
	Std Unit	HGBP	Digital	Std Unit	HGBP	Digital
015	6 (6.5)	4 (4.3)	—	10 (10.8)	10 (10.8)	—
020,030	6 (6.5)	4 (4.3)	3 (3.3)	10 (10.8)	10 (10.8)	6 (6.5)
040,045	3 (3.3)	3 (3.3)	3 (3.3)	6 (6.5)	6 (6.5)	6 (6.5)
050-071	6 (6.5)	4 (4.3)	—	10 (10.8)	10 (10.8)	—

LEGEND

HGBP — Hot Gas Bypass

For process jobs where accuracy is vital or for operation at outdoor ambient temperatures below 32 F (0° C) with low unit loading conditions, there should be from 6 to 10 gal. per ton (6.5 to 10.8 L per kW). To achieve this volume, it is often necessary to install a tank in the loop. Tank should be baffled to ensure there is no stratification, and that water (or brine) entering tank is adequately mixed with liquid in the tank.

NOTE: Tank installation is shown below.

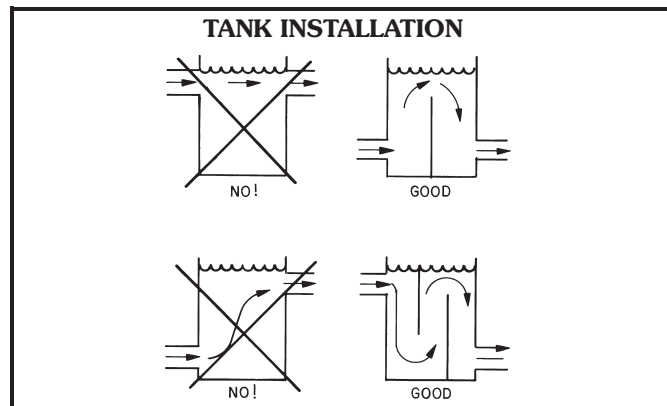

Fouling factor — The factor used to calculate tabulated ratings was 0.00010 ft² • hr • F/Btuh (0.000018 m² • k/W). As fouling factor is increased, unit capacity decreases and compressor power increases. To determine selections at other fouling factors, use chiller program in the electronic catalog.

30MPA remote condenser requirements

- If multiple units are connected to a single condenser, ensure each refrigerant circuit has its own head pressure control.
- Condenser must provide 15° F (8.3° C) subcooling, a maximum of 40° F (22.2° C) difference between saturated condensing temperature and outdoor ambient temperature (to prevent overload at high ambient temperatures), and a minimum of 20° F (11.1° C) difference (to ensure subcooling).
- Do not manifold independent refrigerant circuits into a single condenser.
- If air-cooled condenser is located below chiller, refer to the condenser manufacturer's performance data for available liquid lift.
- Refer to condenser installation instructions for location guidelines.

Oversizing chillers

Oversizing chillers by more than 15% at design conditions must be avoided as the system operating efficiency will be adversely affected (resulting in greater and/or excessive electrical demand and cycling of compressors). When future expansion of equipment is anticipated, install a single chiller to meet present load requirements and install a second chiller to meet the additional load demand.

It is also recommended that the installation of 2 smaller chillers be considered where operation at minimum load is critical. The operation of a smaller chiller loaded to a greater percent of minimum is preferred to operating a single chiller at or near its minimum recommended value.

Hot gas bypass should not be used as a means to allow oversizing chillers. Hot gas bypass should be given consideration where substantial operating time is anticipated below the minimum unloading step.

Application data (cont)



Strainers

A 40 mesh strainer must be installed in the evaporator and condenser fluid inlet lines, within 10 ft (3 m) of the heat exchanger in each line, between the pump and the chiller.

Parallel chillers

Where chiller capacities greater than can be supplied by a single 30MP chiller are required, or where stand-by capability is desired, chillers may be installed in parallel. Units may be of the same or different sizes. However, evaporator and condenser flow rates must be balanced to ensure proper flow to each chiller.

Series chillers

Where a large temperature drop (greater than 25° F [13.9° C]) is desired and higher fluid pressure drop across the evaporator can be tolerated, chillers may be installed in series. The leaving fluid temperature sensors need not be relocated. However, the evaporator minimum entering fluid temperature limitations should be considered for the chillers located downstream of other chillers. Condensers should be piped in parallel to maximize capacity and efficiency. This should also minimize condenser pressure drop and saturated condensing temperatures. However, if condensers are piped in series, ensure that the leaving water temperature does not exceed 140 F (60.0 C).

Energy management

Demand limiting and load shedding are popular techniques used to reduce peak electric demands typically experienced during hot summer days when air conditioning loads are highest. When utility electricity demands exceed a certain level, electrical loads are turned off to keep the peak demands below a prescribed maximum limit. Unit unloading will reduce electrical demand while allowing the chiller to operate under part load capacity and maintain partial chilled fluid cooling. The energy management module can be added to accomplish this.

Electrical demand may be limited by unloading the chiller to a predetermined percentage of the load. One stage of unloading can be initiated by a remote signal to significantly reduce the chiller power consumption. This power reduction applies to the full load power at nominal conditions. The demand limit control should not be cycled less than 10 minutes on and 5 minutes off.

Vibration isolation

All compressors are isolated. External vibration isolation is not generally required, but is available for 30MP units as an accessory if desired.

Evaporator and liquid-cooled condenser freeze protection

If chiller or fluid lines are in an area where ambient conditions fall below 40 F (4.4 C), it is recommended that an antifreeze (brine) solution be added to protect the unit and fluid piping to a temperature 15° F (8.3° C) below the lowest anticipated ambient temperature. In applications where the leaving evaporator fluid temperature is below 32 F (0° C), the medium temperature brine option should be selected so that the freeze point is at least 15° F (8.3° C)

below the evaporator leaving fluid temperature and below the suction temperature at the evaporator.

Use only antifreeze solutions approved for heat exchanger duty. Use of automotive antifreezes is not recommended because of the fouling that can occur once their relatively short-lived inhibitor breaks down.

If not protected with an antifreeze solution, draining evaporator and outdoor piping is recommended if system is not to be used during freezing weather conditions.

Water system overview

A system installed incorrectly such that air is not handled properly — pipe leaks, vent leaks, air in pipes, etc. — may behave as an open system and thus have unsatisfactory operation. Pump seal wear can also cause leaks that cause poor system operation.

Proper system design and installation procedures should be followed closely. The system must be constructed with pressure tight components and thoroughly tested for installation leaks.

Installation of water systems should follow sound engineering practice as well as applicable local and industry standards. Improperly designed or installed systems may cause unsatisfactory operation and/or system failure. Consult a water treatment specialist or appropriate literature for information regarding filtration, water treatment, and control devices.

Water quality should be maintained within the limits indicated in the Water Quality Characteristics and Limitations table.

WATER QUALITY CHARACTERISTICS AND LIMITATIONS

WATER CHARACTERISTIC	QUALITY LIMITATION
Alkalinity (HCO ₃ ⁻)	70 – 300 ppm
Sulfate (SO ₄ ²⁻)	Less than 70 ppm
HCO ₃ ⁻ /SO ₄ ²⁻	Greater than 1.0
Electrical Conductivity	10 – 500 µS/cm
pH	7.5 – 9.0
Ammonium (NH ₃)	Less than 2 ppm
Chlorides (Cl ⁻)	Less than 300 ppm
Free Chlorine (Cl ₂)	Less than 1 ppm
Hydrogen Sulfide (H ₂ S)*	Less than 0.05 ppm
Free (aggressive) Carbon Dioxide (CO ₂)†	Less than 5 ppm
Total Hardness (dH)	4.0 – 8.5
Nitrate (NO ₃)	Less than 100 ppm
Iron (Fe)	Less than 0.2 ppm
Aluminum (Al)	Less than 0.2 ppm
Manganese (Mn)	Less than 0.1 ppm

*Sulfides in the water quickly oxidize when exposed to air, requiring that no agitation occur as the sample is taken. Unless tested immediately at the site, the sample will require stabilization with a few drops of one Molar zinc acetate solution, allowing accurate sulfide determination up to 24 hours after sampling. A low pH and high alkalinity cause system problems, even when both values are within the ranges shown. The term pH refers to the acidity, basicity, or neutrality of the water supply. Below 7.0, the water is considered to be acidic. Above 7.0, water is considered to be basic. Neutral water contains a pH of 7.0.

†Dissolved carbon dioxide can either be calculated from the pH and total alkalinity values, shown below, or measured on the site using a test kit. Dissolved Carbon Dioxide, PPM = TA x 2^[(6.3-pH)/0.3] where TA = Total Alkalinity, PPM as CaCO₃.

30MPA REFRIGERANT PIPING

SINGLE CIRCUIT LINE 30MPA LINE SIZING CHART

30MPA UNIT	UNIT REFRIGERANT CONNECTIONS (CHILLER CONNECTION SIZE) ODS		TOTAL LINEAR LENGTH OF INTERCONNECTING PIPE FT (M)					
			0 - 50 (0 - 15.4) EQUIV. PIPE LENGTH = 75 FT		50 - 100 (15.4 - 30.5) EQUIV. PIPE LENGTH = 150 FT		100 - 200 (30.5 - 61.0) EQUIV. PIPE LENGTH = 300 FT	
			L (IN.)	D (IN.)	L (IN.)	D (IN.)	L (IN.)	D (IN.)
015	1/2	1 3/8	1/2	1 3/8	5/8	1 3/8	5/8	1 3/8
020	1/2	1 3/8	5/8	1 3/8	5/8	1 3/8	7/8	1 3/8
030	5/8	1 3/8	7/8	1 3/8	7/8	1 3/8	7/8	1 3/8
040	5/8	1 5/8	7/8	1 5/8	7/8	1 5/8	1 1/8	1 5/8
045	5/8	1 5/8	7/8	1 5/8	7/8	1 5/8	1 1/8	1 5/8
050	1 1/8	1 5/8	1 1/8	1 5/8	1 1/8	2 1/8	1 3/8	2 1/8
055	1 1/8	1 5/8	1 1/8	1 5/8	1 1/8	2 1/8	1 3/8	2 1/8
060	1 1/8	1 5/8	1 1/8	2 1/8	1 1/8	2 1/8	1 3/8	2 5/8
065	1 1/8	1 5/8	1 1/8	2 1/8	1 1/8	2 1/8	1 3/8	2 5/8
071	1 1/8	1 5/8	1 1/8	2 1/8	1 1/8	2 1/8	1 3/8	2 5/8

LEGEND

- D — Discharge Line Size (discharge line size is equal to the chiller connection size)
- L — Liquid Line Size (liquid line size is equal to or greater than the chiller connection size)

NOTES:

1. Shaded areas indicate double discharge riser required if unit is equipped with hot gas bypass or operation below 40 F (4.4 C) LWT (leaving water [fluid] temperature).
2. All units with digital compressors require double discharge riser.

DOUBLE DISCHARGE RISER DATA

30MPA UNIT	TOTAL LINEAR LENGTH OF INTERCONNECTING PIPE ft (m)		MINIMUM TONNAGE WITH DOUBLE RISER
	0 - 200 (0 - 61.0)		
	Riser A D (in.)	Riser B D (in.)	
015	7/8	1 1/8	1.86
020	7/8	1 1/8	1.86
030	7/8	1 1/8	1.86
040	7/8	1 3/8	1.86
045	7/8	1 3/8	1.86
050	1 5/8	1 5/8	3.16
055	1 5/8	1 5/8	3.16
060	1 5/8	2 1/8	3.16
065	1 5/8	2 1/8	3.16
071	1 5/8	2 1/8	3.16

LIQUID LINE REFRIGERANT CHART

PIPE DIAMETER (in.)	POUNDS PER 10 LINEAR FEET (kg per 3 m)
1/2	0.6 (0.27)
5/8	1.0 (0.45)
7/8	2.0 (0.91)
1 1/8	3.5 (1.58)
1 3/8	5.1 (2.32)

DOUBLE DISCHARGE RISER CONSTRUCTION DETAIL

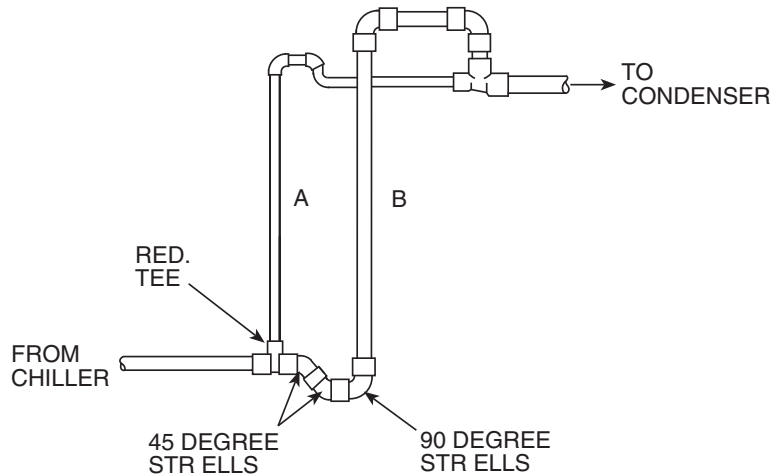

LEGEND

- RED. TEE — Reducing Tee
- STR ELLS — Street Elbows

Application data (cont)



Insulation

Insulation for 30MP units includes compressor insulation (available as either factory-installed option or field-installed accessory), and factory-installed insulation of suction line to compressors, evaporator, and expansion valve and the line running from expansion valve to evaporator. Field-supplied and installed insulation is recommended for water lines.

As indicated in the Condensation vs Relative Humidity table, the factory insulation provides excellent protection against condensation under most operating conditions. If temperatures in the equipment area exceed the maximum design conditions, extra insulation is recommended.

CONDENSATION VS RELATIVE HUMIDITY*

AMOUNT OF CONDENSATION	ROOM DRY-BULB TEMP		
	80 F (27 C)	90 F (32 C)	100 F (38 C)
None	80	76	70
Slight	87	84	77
Extensive	94	91	84

*These approximate figures are based on 35 F (1.7 C) saturated suction temperature. A 2° F (1.1° C) change in saturated suction temperature changes the relative humidity values by 1% in the same direction.

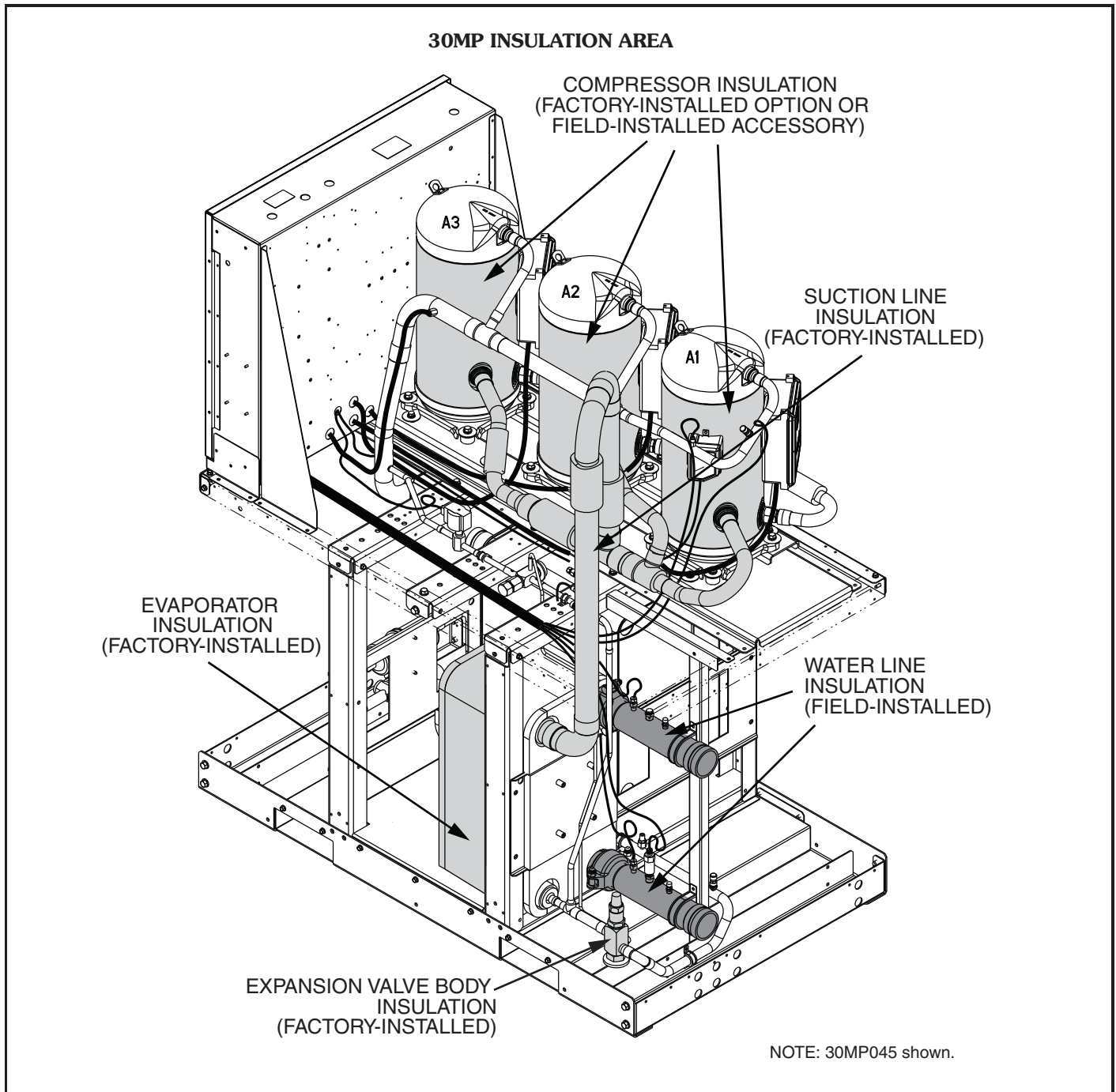

Selection procedure



Carrier's packaged selection program provides quick, easy selection of Carrier's liquid-cooled chillers. The program considers specific temperature, fluid and flow requirements among other factors such as fouling and altitude corrections. Before selecting a chiller, consider the following points:

Leaving water (fluid) temperature (LWT):

- The LWT must be at least 40 F (4.4 C) or greater for fresh water applications.
- If the LWT is greater than 32 F (0° C) and less than 40 F (4.4 C), select the standard unit and ensure a suitable brine solution in the water loop.
- If the LWT is below 32 F (0° C), select the medium temperature brine option.
- If the LWT requirement is greater than 60 F (15.5 C), a mixing loop is required.

Entering water (fluid) temperature (EWT):

- If the EWT requirement is greater than 70 F (21.1 C), a mixing loop is required. The EWT should not exceed 75 F (23.9 C) for extended operation. Pulldown can be accomplished from 95 F (35 C).

Evaporator flow rate or evaporator delta-T:

- The evaporator delta-T (EWT – LWT) must fall between 5 and 20° F (2.8 and 11.1° C) while still meeting the maximum entering requirements.

- For larger or smaller delta-T applications, a mixing loop is required. If the evaporator flow is variable, the rate of change of flow should not exceed 10% per minute. The loop volume in circulation must equal or exceed 3 gallons per nominal ton (3.2 L per kW) of cooling for temperature stability and accuracy in normal air conditioning applications. In process cooling applications, there should be 6 to 10 gallons per ton (6.5 to 10.8 L per kW). To achieve this loop volume, it is often necessary to install a tank in the loop. The tank should be baffled to ensure there is no stratification, and that water (or brine) entering the tank is adequately mixed with liquid in the tank. See Chilled Fluid Loop Volume in the Application Data section on page 23.

Water quality, fouling factor:

- Poor water quality can increase the required evaporator fouling factor.
- Higher than standard fouling factors lead to lower capacity and higher input kW from a given chiller size compared to running the same application with better water quality (and lower fouling factors).

EVAPORATOR AND CONDENSER PRESSURE DROP CURVES
EVAPORATOR PRESSURE DROP CURVE, STANDARD UNITS — ENGLISH

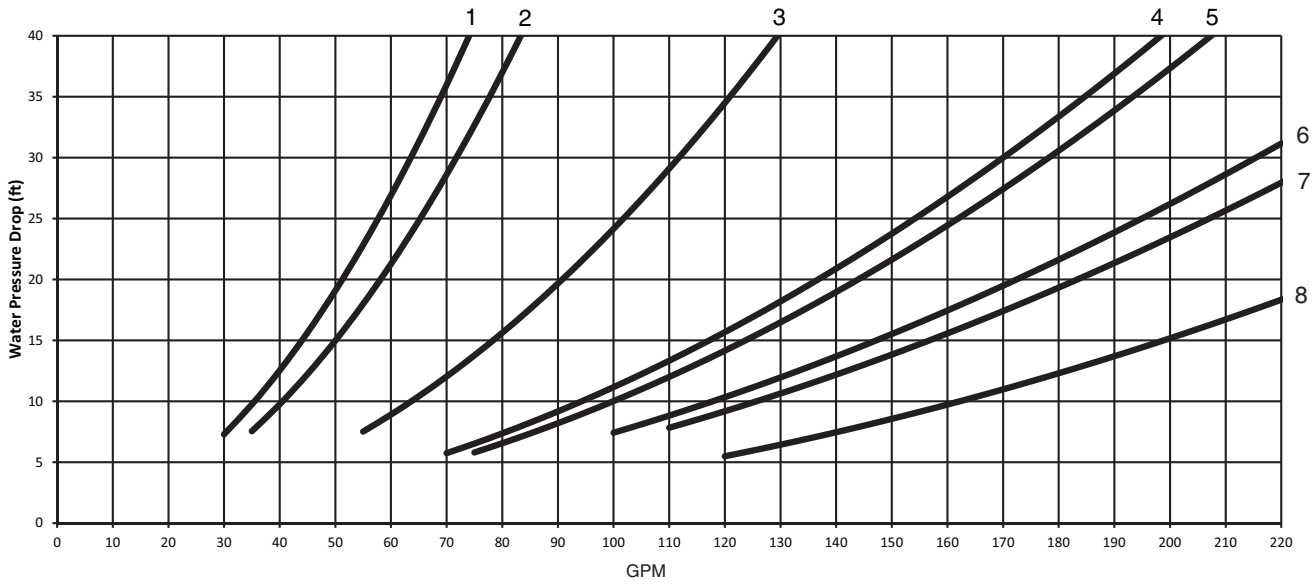

EVAPORATOR PRESSURE DROP CURVE, STANDARD UNITS — SI

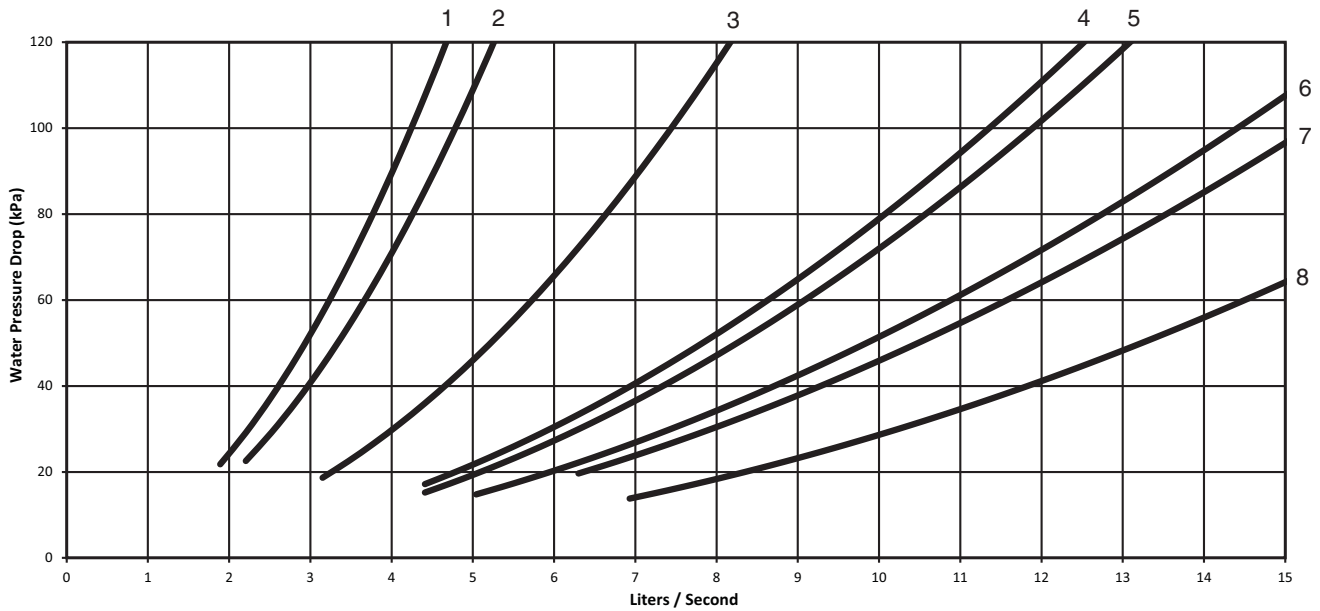

LEGEND

- | | |
|-------------|-----------------|
| 1 — 30MP015 | 6 — 30MP050,055 |
| 2 — 30MP020 | 7 — 30MP060,065 |
| 3 — 30MP030 | 8 — 30MP071 |
| 4 — 30MP040 | |
| 5 — 30MP045 | |

EVAPORATOR AND CONDENSER PRESSURE DROP CURVES (cont)
EVAPORATOR PRESSURE DROP CURVE, STYLE A* MANIFOLD UNITS — ENGLISH

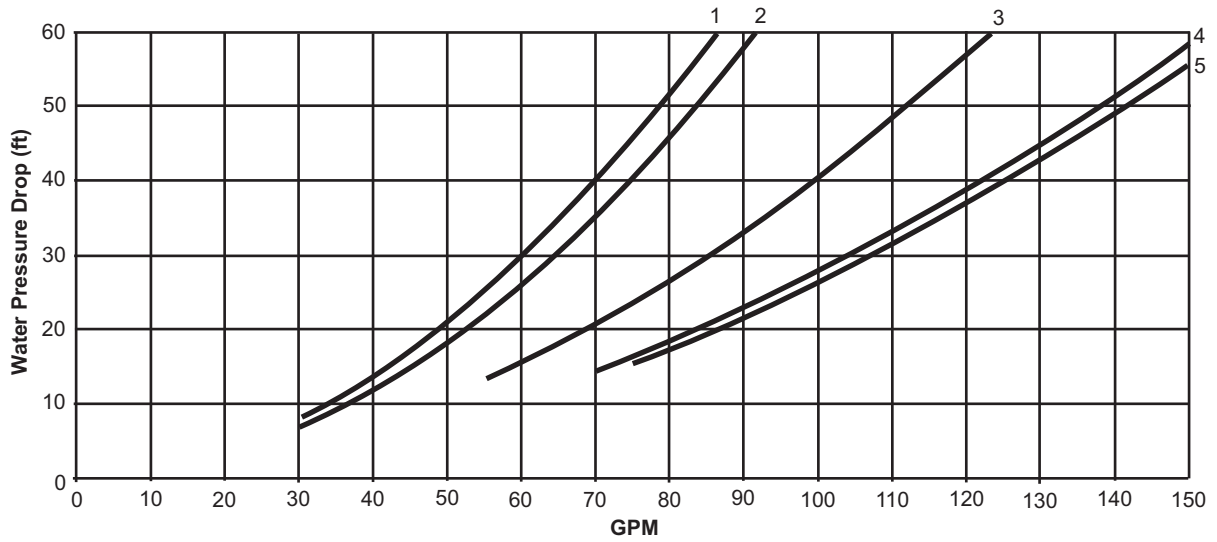

EVAPORATOR PRESSURE DROP CURVE, STYLE A* MANIFOLD UNITS — SI

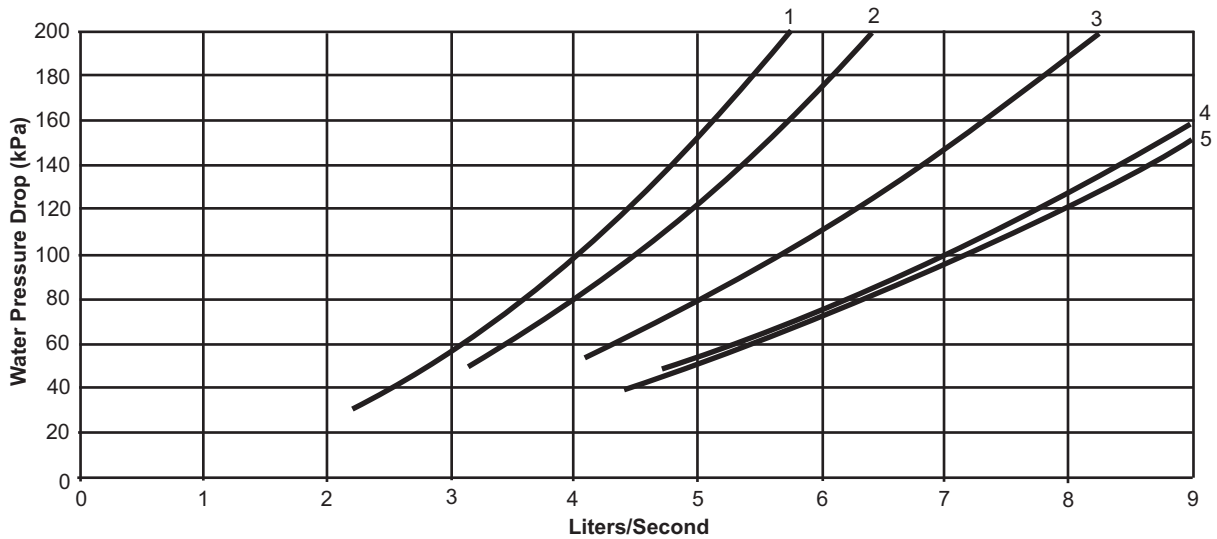

LEGEND

- 1 — 30MP015
- 2 — 30MP020
- 3 — 30MP030
- 4 — 30MP040
- 5 — 30MP045

*Style A manifold is used on 30MP015-045 units manufactured prior to November 2015.

Performance data (cont)



EVAPORATOR AND CONDENSER PRESSURE DROP CURVES (cont)

EVAPORATOR PRESSURE DROP CURVE, STYLE B* MANIFOLD UNITS — ENGLISH

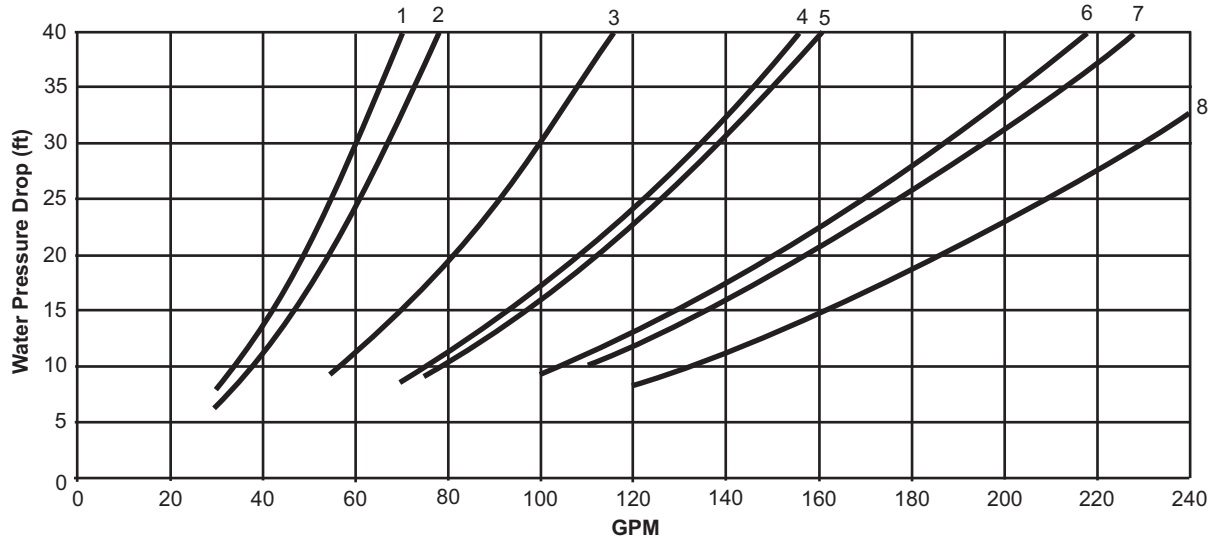

EVAPORATOR PRESSURE DROP CURVE, STYLE B* MANIFOLD UNITS — SI

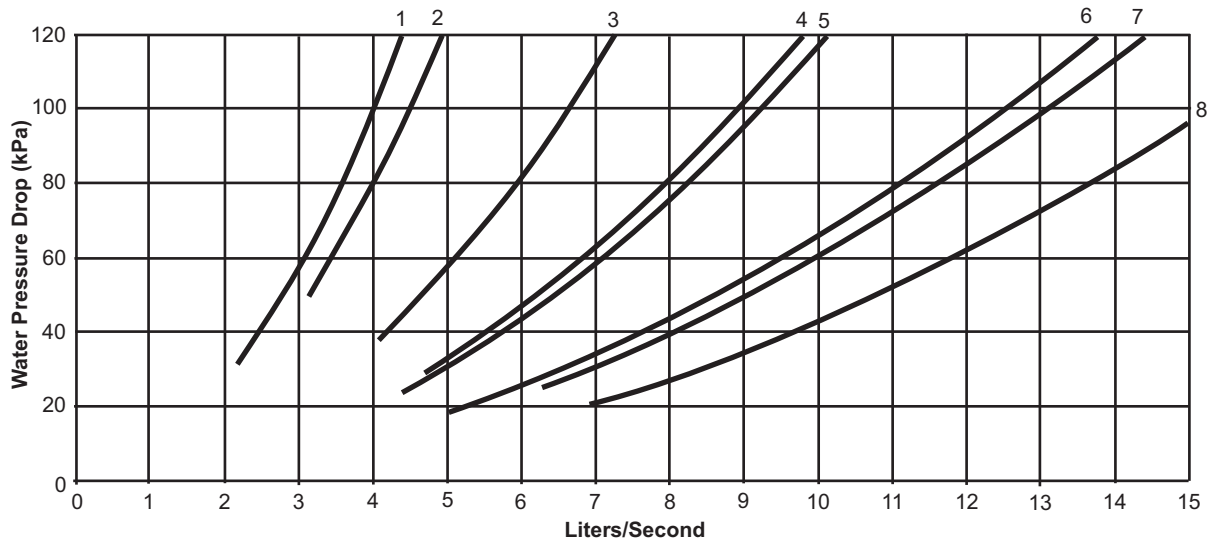

LEGEND

- 1 — 30MP015 6 — 30MP050,055
- 2 — 30MP020 7 — 30MP060,065
- 3 — 30MP030 8 — 30MP071
- 4 — 30MP040
- 5 — 30MP045

*Style B manifold is used on 30MP015-071 units manufactured starting November 2015.

EVAPORATOR AND CONDENSER PRESSURE DROP CURVES (cont)

CONDENSER PRESSURE DROP CURVE, STANDARD UNITS — ENGLISH

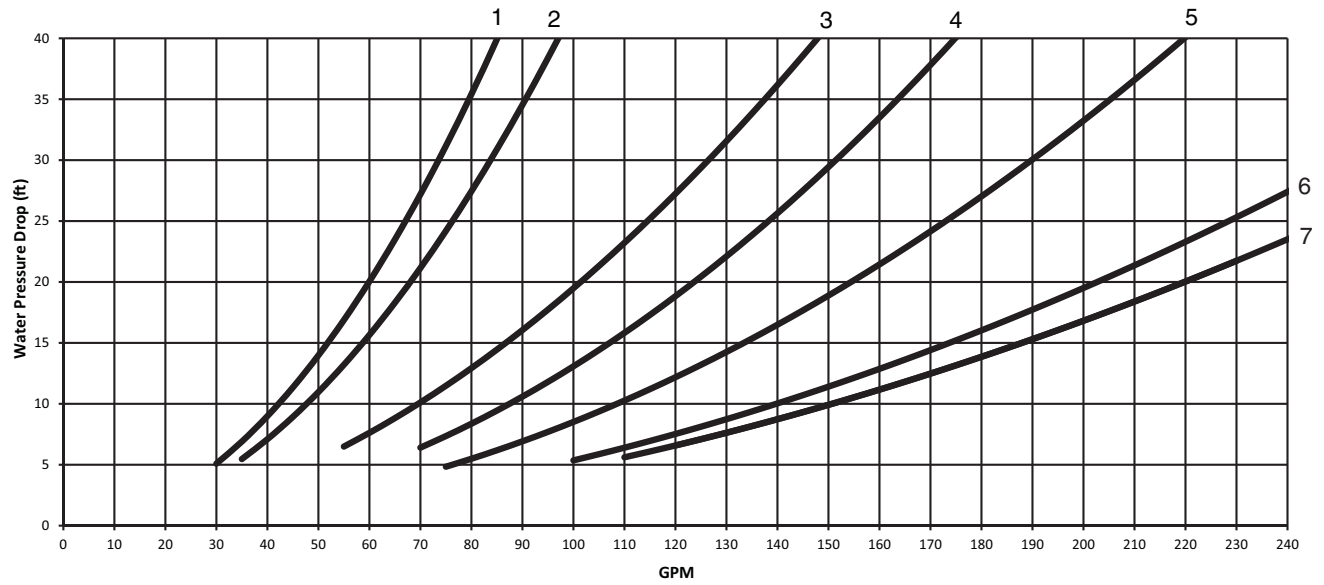

CONDENSER PRESSURE DROP CURVE, STANDARD UNITS — SI

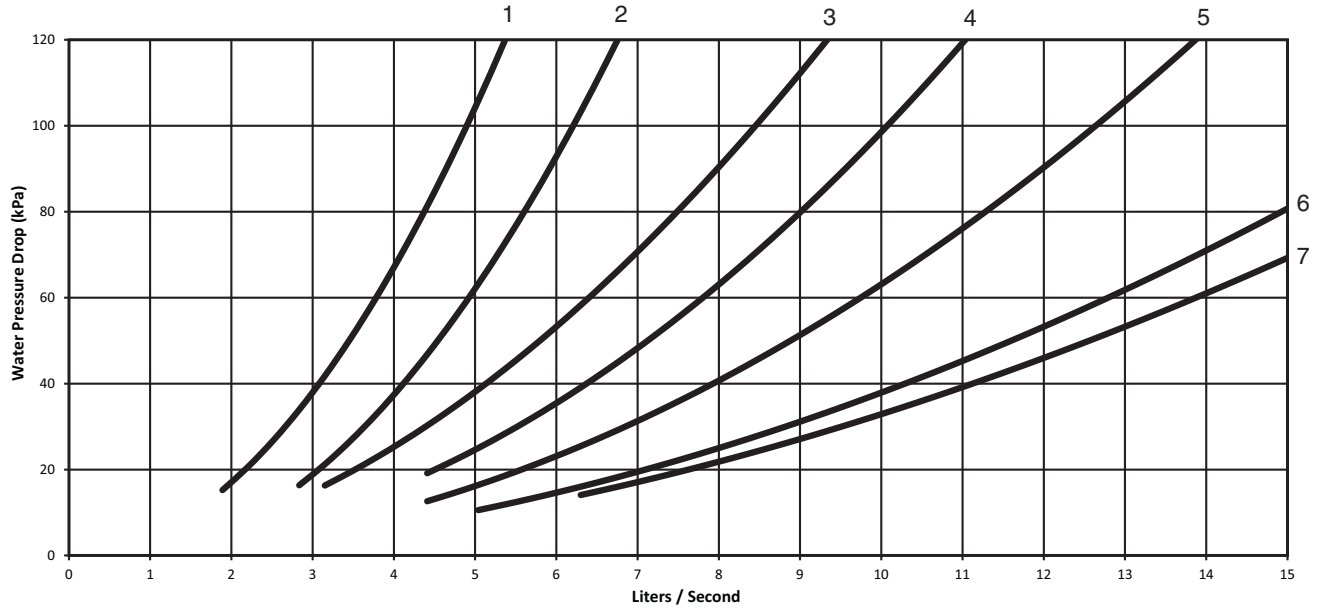

LEGEND

- 1 — 30MP015
- 2 — 30MP020
- 3 — 30MP030
- 4 — 30MP040
- 5 — 30MP045
- 6 — 30MP050,055
- 7 — 30MP060,065,071

EVAPORATOR AND CONDENSER PRESSURE DROP CURVES (cont)

CONDENSER PRESSURE DROP CURVE, STYLE A* MANIFOLD UNITS — ENGLISH

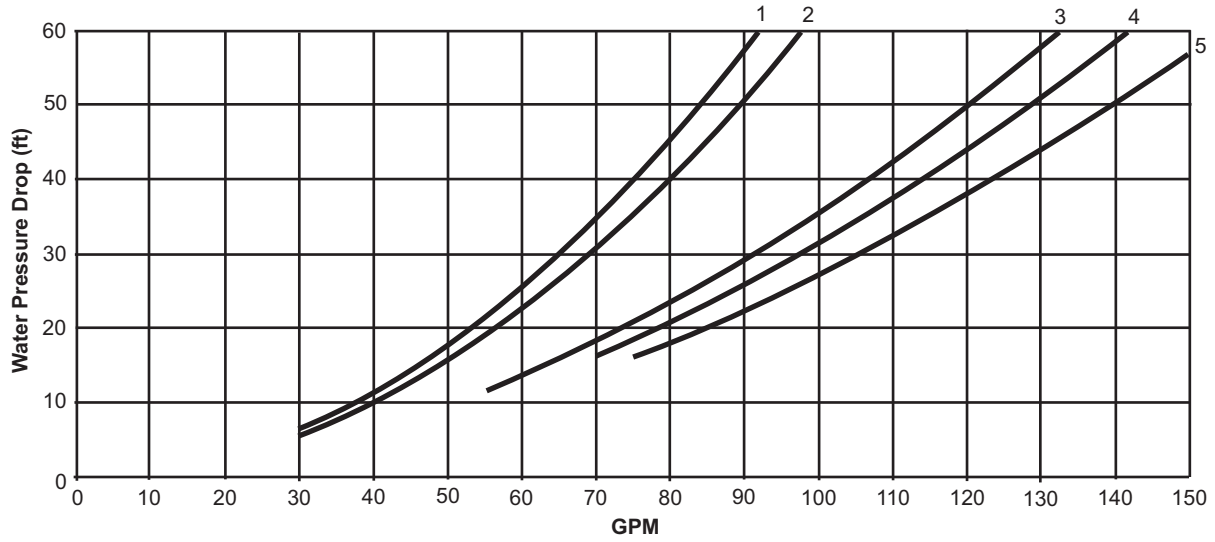

CONDENSER PRESSURE DROP CURVE, STYLE A* MANIFOLD UNITS — SI

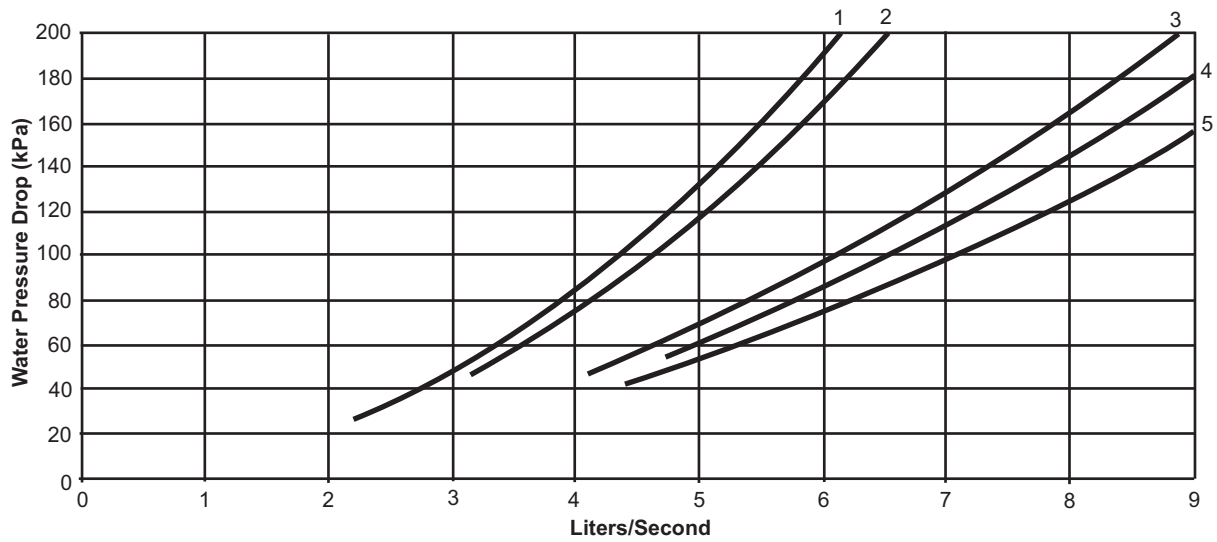

LEGEND

- 1 — 30MP015
- 2 — 30MP020
- 3 — 30MP030
- 4 — 30MP040
- 5 — 30MP045

*Style A manifold is used on 30MP015-045 units manufactured prior to November 2015.

EVAPORATOR AND CONDENSER PRESSURE DROP CURVES (cont)

CONDENSER PRESSURE DROP CURVE, STYLE B* MANIFOLD UNITS — ENGLISH

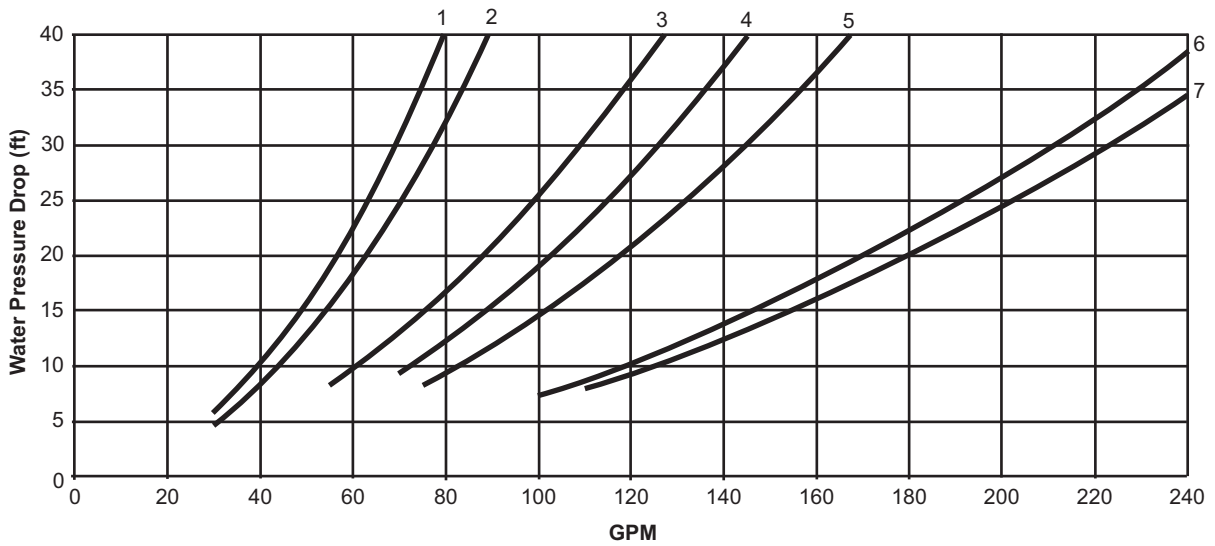

CONDENSER PRESSURE DROP CURVE, STYLE B* MANIFOLD UNITS — SI

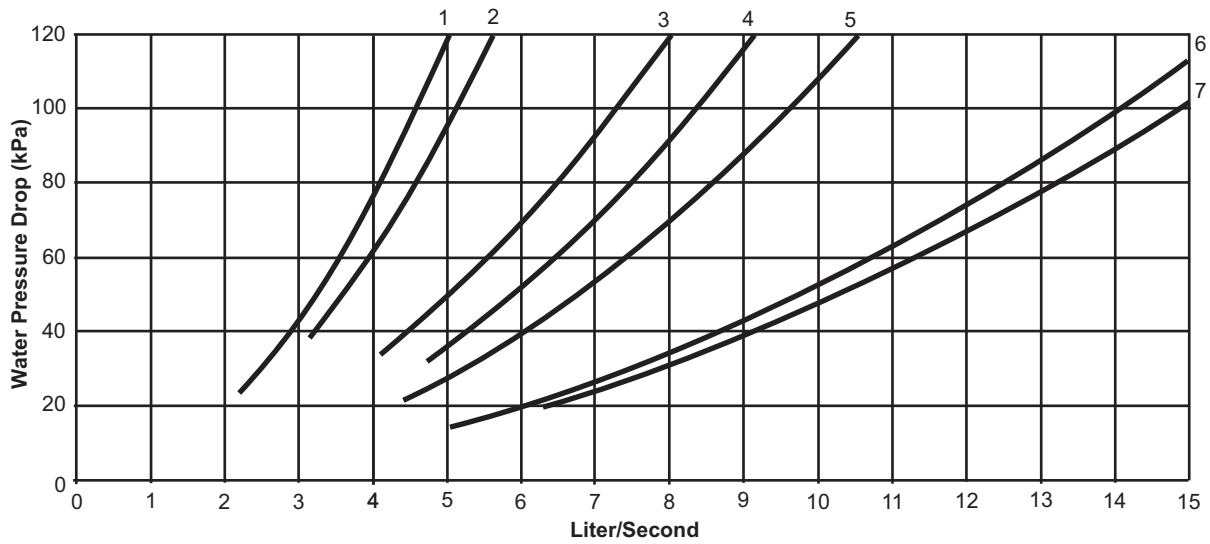

LEGEND

- 1 — 30MP015
- 2 — 30MP020
- 3 — 30MP030
- 4 — 30MP040
- 5 — 30MP045
- 6 — 30MP0050,055
- 7 — 30MP060-071

*Style B manifold is used on 30MP015-071 units manufactured starting November 2015.

Electrical data



30MPA,MPW015-045 UNITS

UNIT SIZE 30MPA,MPW	VOLTS NAMEPLATE	VOLTAGE*		COMPRESSOR			UNIT			
		Min	Max	Quantity	RLA (ea)	LRA (ea)	MCA	ICF	MOCP	Rec Fuse
015	208/230-3-60	187	253	2	29.5	195	66.4	224.5	90	80
	380-3-60	342	418		16.7	123	37.6	139.7	50	45
	460-3-60	414	508		14.7	95	33.1	109.7	45	40
	575-3-60	518	632		12.2	80	27.5	92.2	35	35
	380/415-3-50	342	440		14.7	95	33.12	109.7	45	40
020	208/230-3-60	187	253	2	35.8	239	80.6	274.8	110	90
	380-3-60	342	418		23.7	145	53.4	168.7	70	60
	460-3-60	414	508		17.9	125	40.3	142.9	50	45
	575-3-60	518	632		14.3	80	32.2	94.3	45	40
	380/415-3-50	342	440		20.0	118	45.0	138.0	60	60
030	208/230-3-60	187	253	2	55.8	340	125.6	395.8	175	150
	380-3-60	342	418		34.0	196	76.5	230.0	110	90
	460-3-60	414	508		26.9	179	60.5	205.9	80	70
	575-3-60	518	632		23.7	132	53.3	155.7	70	60
	380/415-3-50	342	440		28.6	174	64.3	202.6	90	80
040	208/230-3-60	187	253	3	51.3	300	166.7	402.6	200	200
	380-3-60	342	418		26.9	139	87.4	192.8	110	100
	460-3-60	414	508		23.1	150	75.1	196.2	90	90
	575-3-60	518	632		19.9	109	64.7	148.8	80	70
	380/415-3-50	342	440		25.0	140	81.3	190.0	100	90
045	208/230-3-60	187	253	3	55.8	340	181.4	451.6	225	200
	380-3-60	342	418		34.0	196	110.5	264.0	125	125
	460-3-60	414	508		26.9	179	87.4	232.8	110	100
	575-3-60	518	632		23.7	132	77.0	179.4	100	90
	380/415-3-50	342	440		28.6	174	92.9	231.1	110	110

LEGEND

- AWG** — American Wire Gage
- ICF** — Maximum instantaneous current flow during starting
- kcmil** — Thousand circular mils
- LRA** — Locked Rotor Amps
- MCA** — Minimum Circuit Amps (for wire sizing). Complies with NEC, Section 430-24.
- MOCP** — Maximum Overcurrent Protection
- Rec Fuse** — Recommended dual element fuse amps (150% of compressor RLA). Size up to the next standard fuse size.
- RLA** — Rated Load Amps

3/0 for unit sizes:

- 015,020; 208/230-3-60 voltages.
 - 020-040; 380-3-60 voltage.
 - 030-045; 460-3-60, 380/415-3-50 and 575-3-60 voltages.
- 2 AWG for unit sizes:
- 015: 380-3-60 voltage.
 - 015,020; 460-3-60, 380/415-3-50 and 575-3-60 voltages.

3. Additional control circuit power is not required.
4. Any field modification of factory wiring must be in compliance with all applicable codes. Field-installed power wires must be rated 75 C minimum.
5. Use copper conductors only.
6. Control circuit power supply is 24-v single phase. Control power is supplied by the factory-installed control transformer.

NOTES:

1. All units have one field power terminal block.
2. Maximum incoming wire size is as follows:
For units with terminal block:
350 kcmil for unit sizes 030-045; 208/230-3-60 voltages.
2/0 for unit sizes 015-045; all other voltages.
For units with optional non-fused disconnect:
350 kcmil for unit sizes:
030-045; 208/230-3-60 voltages.
045; 380-3-60 voltage.



Intertek

30MPA,MPW050-071 UNITS WITH HIGH CONDENSING OPTION

UNIT SIZE 30MPA,MPW	VOLTS NAMEPLATE	VOLTAGE*		COMPRESSOR A1		COMPRESSOR A2		UNIT			
		MIN	MAX	RLA	LRA	RLA	LRA	MCA	ICF	MOCP	REC FUSE
050	208/230-3-60	187	253	85.1	436	85.1	436	191.5	521.1	250	225
	380-3-60	342	418	49.3	252	49.3	252	110.9	301.3	150	125
	460-3-60	414	508	40.7	212	40.7	212	91.6	252.7	125	110
	575-3-60	518	632	32.6	168	32.6	168	73.4	200.6	100	90
	380/415-3-50	342	440	40.7	212	40.7	212	91.6	252.7	125	110
055	208/230-3-60	187	253	85.1	436	106.2	578	217.9	663.1	300	250
	380-3-60	342	418	49.3	252	64.3	355	129.7	404.3	175	150
	460-3-60	414	508	40.7	212	53.1	290	107.1	330.7	150	125
	575-3-60	518	632	32.6	168	42.5	255	85.7	287.6	125	100
	380/415-3-50	342	440	40.7	212	53.1	290	107.1	330.7	150	125
060	208/230-3-60	187	253	85.1	436	102.8	635	213.6	720.1	300	250
	380-3-60	342	418	49.3	252	62.2	355	127.1	404.3	175	150
	460-3-60	414	508	40.7	212	51.4	280	105.0	320.7	150	125
	575-3-60	518	632	32.6	168	41.1	225	84.0	257.6	125	100
	380/415-3-50	342	440	40.7	212	51.4	280	105.0	320.7	150	125
065	208/230-3-60	187	253	85.1	436	128.2	602	245.4	687.1	350	300
	380-3-60	342	418	49.3	252	77.6	367	146.3	416.3	200	175
	460-3-60	414	508	40.7	212	64.1	298	120.8	338.7	175	150
	575-3-60	518	632	32.6	168	51.3	229	96.7	261.6	125	110
	380/415-3-50	342	440	40.7	212	64.1	298	120.8	338.7	175	150
071	208/230-3-60	187	253	106.2	578	128.2	602	266.5	708.2	350	300
	380-3-60	342	418	64.3	355	77.6	367	161.3	431.3	225	200
	460-3-60	414	508	53.1	290	64.1	298	133.2	351.1	175	150
	575-3-60	518	632	42.5	255	51.3	229	106.6	297.5	150	125
	380/415-3-50	342	440	53.1	290	64.1	298	133.2	351.1	175	150

LEGEND

- ICF** — Maximum instantaneous current flow during starting.
- kcmil** — Thousand circular mils
- LRA** — Locked Rotor Amps
- MCA** — Minimum Circuit Amps (for wire sizing). Complies with NEC, Section 430-24.
- MOCP** — Maximum Overcurrent Protection
- Rec Fuse** — Recommended dual element fuse amps (150% of compressor RLA). Size up to the next standard fuse size.
- RLA** — Rated Load Amps

- 4. Any field modification of factory wiring must be in compliance with all applicable codes. Field-installed power wires must be rated 75 C minimum.
- 5. Use copper conductors only.
- 6. Control circuit power supply is 24-v single phase. Control power is supplied by the factory-installed control transformer.

*Supply Range — Units are suitable for use on electrical systems where voltage supplied to the unit terminals is not below or above the listed range limits.

NOTES:

1. All units have one field power terminal block.
2. Maximum incoming wire size is as follows:
 For units with terminal block:
 500 kcmil for all unit sizes 050-071; all voltages
 For units with optional non-fused disconnect:
 350 kcmil for unit sizes 050-071, 208/230-3-60 voltages.
 3/0 for all other voltages.
3. Additional control circuit power is not required.



Intertek

Electrical data (cont)



30MPW050-071 UNITS WITHOUT HIGH CONDENSING OPTION

UNIT SIZE 30MPW	VOLTS NAMEPLATE	VOLTAGE*		COMPRESSOR A1		COMPRESSOR A2		UNIT			
		MIN	MAX	RLA	LRA	RLA	LRA	MCA	ICF	MOCP	REC FUSE
050	208/230-3-60	187	253	79.4	418	79.4	418	178.7	497.1	250	200
	380-3-60	342	418	48.1	252	48.1	252	108.2	300.3	150	125
	460-3-60	414	508	39.7	212	39.7	212	89.3	251.9	125	100
	575-3-60	518	632	31.8	168	31.8	168	71.6	199.9	100	80
	380/415-3-50	342	440	39.7	212	39.7	212	89.3	251.9	125	100
055	208/230-3-60	187	253	79.4	418	98.4	477	202.4	556.7	300	250
	380-3-60	342	418	48.1	252	59.5	299	122.5	346.8	175	150
	460-3-60	414	508	39.7	212	49.2	241	101.2	280.4	150	125
	575-3-60	518	632	31.8	168	39.3	194	80.9	225.4	110	100
	380/415-3-50	342	440	39.7	212	49.2	241	101.2	280.4	150	125
060	208/230-3-60	187	253	79.4	418	106.7	582	212.8	661.7	300	250
	380-3-60	342	418	48.1	252	64.6	355	128.9	403.2	175	150
	460-3-60	414	508	39.7	212	53.4	280	106.5	320.1	150	125
	575-3-60	518	632	31.8	168	42.7	225	85.2	256.7	125	100
	380/415-3-50	342	440	39.7	212	53.4	280	106.5	320.1	150	125
065	208/230-3-60	187	253	79.4	418	112.5	578	220.0	657.8	300	250
	380-3-60	342	418	48.1	252	67.2	355	132.1	403.5	175	150
	460-3-60	414	508	39.7	212	55.5	290	109.1	329.9	150	125
	575-3-60	518	632	31.8	168	44.4	255	87.3	286.7	125	100
	380/415-3-50	342	440	39.7	212	55.5	290	109.1	329.9	150	125
071	208/230-3-60	187	253	98.4	477	112.5	578	239.0	676.8	350	300
	380-3-60	342	418	59.5	299	67.2	355	143.5	414.9	200	175
	460-3-60	414	508	49.2	241	55.5	290	118.6	339.4	150	150
	575-3-60	518	632	39.3	194	44.4	255	94.8	294.2	125	110
	380/415-3-50	342	440	49.2	241	55.5	290	118.6	339.4	150	150

LEGEND

- ICF** — Maximum instantaneous current flow during starting.
- kcmil** — Thousand circular mils
- LRA** — Locked Rotor Amps
- MCA** — Minimum Circuit Amps (for wire sizing). Complies with NEC, Section 430-24.
- MOCP** — Maximum Overcurrent Protection
- Rec Fuse** — Recommended dual element fuse amps (150% of compressor RLA). Size up to the next standard fuse size.
- RLA** — Rated Load Amps

4. Any field modification of factory wiring must be in compliance with all applicable codes. Field-installed power wires must be rated 75 C minimum.
5. Use copper conductors only.
6. Control circuit power supply is 24-v single phase. Control power is supplied by the factory-installed control transformer.

*Supply Range — Units are suitable for use on electrical systems where voltage supplied to the unit terminals is not below or above the listed range limits.

NOTES:

1. All units have one field power terminal block.
2. Maximum incoming wire size is as follows:
For units with terminal block:
500 kcmil for unit sizes 050-071; all voltages.
For units with optional non-fused disconnect:
350 kcmil for unit sizes 050-071, 208/230-3-60 voltages.
3/0 for all other voltages.
3. Additional control circuit power is not required.



Intertek

The controls consist of 24-v control circuits. The 24-v circuit provides control power for the *ComfortLink* microprocessor control, all safeties, and the interlock relays.

Microprocessor

The *ComfortLink* microprocessor controls overall unit operation. Its central executive routine controls a number of processes simultaneously. These include internal timers, reading inputs, analog to digital conversions, display control, diagnostic control, output relay control, demand limit, capacity control, and temperature reset. Some processes are updated almost continuously, others every 2 to 3 seconds, and some every 30 seconds.

The microprocessor routine is started by switching the Emergency ON-OFF switch (switch 2) to ON position.

Scrolling marquee display

Standard control includes a four-digit alphanumeric display that shows all of the *ComfortLink* control codes (with expandable clear language), plus set points, time of day, and temperatures.

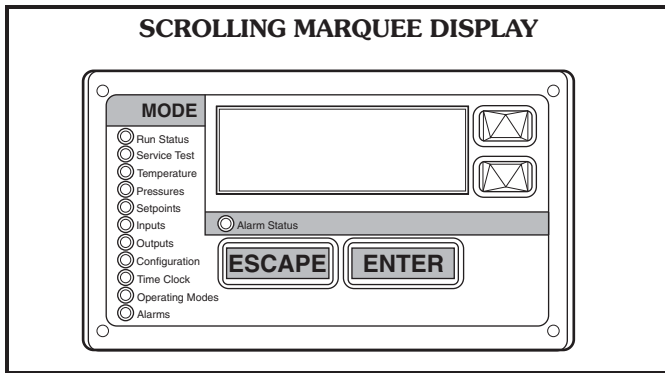

Off cycle

On 30MPA units, during an off cycle, the crankcase heaters remain energized. The crankcase heaters are energized any time all of the compressors in the circuit are off.

Start-up

When the unit Enable/Off/Remote switch is set to the ENABLE position, the 24-v control circuit will be energized. When there is a call for cooling and all safety devices are satisfied, the compressor will be started after a delay of 2 to 5 seconds. The low pressure switch will be bypassed, and the compressor unloaders will remain energized during a 2-minute time delay after the compressor has been started.

Capacity control

The 30MP015-030 and 30MP050-071 units have 2 standard stages of capacity control and the 30MP040 and 045 units have 3 standard stages of capacity control. The standard capacity staging is provided by compressor staging. One additional stage of capacity control can be provided by the optional hot gas bypass.

When the leaving fluid temperature rises above the set point, the control will begin to add stages of capacity by starting a compressor. The control uses a leaving-water temperature control with entering water compensation

routine and will add additional stages of capacity as required to meet the required load. If the unit is equipped with hot gas bypass, the hot gas bypass solenoid and a compressor for the circuit will be energized as the first stage of capacity. When the leaving-fluid temperature starts falling below the set point, the control will remove stages of capacity to match the decrease in building load.

On units equipped with the digital compressor option, the controls integrate the modulation of the digital compressor into the capacity routine to match cooling load requirements. The digital compressor provides 22 capacity steps on sizes 020 and 030, and 33 capacity steps on sizes 040 and 045.

The digital scroll option provides better capacity control by incrementally modulating capacity effectively, increasing the number of compression stages compared to chillers that are not equipped with this option.

The digital scroll compressor is not a variable speed device. Instead, it modulates the capacity output by allowing the scroll sets to separate during operation, alternating between full capacity and zero capacity. Utilizing a fixed time-frame ratio, the percentage of time that the scroll set is engaged is the percentage capacity of that compressor.

There are two major advantages of this type of capacity control. First, there is closer capacity control operation with all the available capacity steps compared to the on/off cycling control of conventional scrolls. Second, there is much less of a wear factor on digital scrolls compared to standard scroll compressors because the digital scrolls are not subject to as many shutdown/restart cycles as conventional scrolls. Digital scrolls, rather than shutting off, tend to remain on as they vary to deliver the correct capacity.

Dual chiller control

The *ComfortLink* controller allows 2 chillers (piped in parallel) to operate as a single chilled water plant with standard control functions coordinated through the master chiller controller. This standard *ComfortLink* feature requires a communication link between the 2 chillers and an additional thermistor and well in the common supply line.

Safeties

Loss of charge — This safety will lock out the compressor if the refrigerant pressure falls below the minimum permissible level. See base unit controls and troubleshooting literature for loss of charge logic.

High-pressure cutout — This protection will lock out the compressor if the compressor discharge pressure rises above the cutout setting. See base unit controls and troubleshooting literature for pressure settings.

Compressor circuit breakers — Provided for short circuit protection.

Sensor failure protection — Failures are detected for all thermistors by the microprocessor.

Loss-of-flow protection — Loss-of-flow protection is provided by monitoring the standard proof-of-flow switch.

Compressor anti-cycling — This feature limits compressor cycling.

Controls (cont)



Freeze protection

This safety feature is provided by monitoring of the leaving fluid temperature. If the leaving chilled-fluid temperature falls below the unit freeze point, then the unit will shut off immediately.

Diagnostics

Microprocessor may be put through service test (see Controls, Start-Up, Operation, Service and Troubleshooting literature) without additional equipment or tools. Service test confirms microprocessor is functional, informs observer through display the condition of each sensor and switch in chiller, and allows observer to check for proper operation of control and compressor(s).

Sensors

The standard unit is provided with entering fluid, leaving fluid, suction pressure, and discharge pressure transducers. Additional sensors can be added for condenser entering water temperature, leaving water temperature, space temperature, outdoor air temperature, or suction gas temperature to provide additional diagnostics and control features.

Default settings

To facilitate quick start-ups, all chillers with *ComfortLink* controls are pre-configured with a default setting that assumes stand-alone operation supplying 44 F (6.7 C) chilled water.

Configuration setting will be based on any options or accessories included with the unit at the time of manufacturing. Date and time are set to U.S.A. eastern time zone and will need reconfiguring based on location and local time zone. If operation based on occupancy scheduling is desired, this will also need to be set during installation.

Remote alarm

A 24-v alarm signal will be provided to a remote location in the event of a lockout condition.

Demand limit switch

Demand limiting can be accomplished through switch input or by a field-supplied 4 to 20 mA signal. For either case, Energy Management Module option (also available as an accessory) is required. The field-supplied, normally open contacts (single or pair) can be used to reduce the total chiller electrical demand during times of peak usage. This is accomplished by reducing the number of capacity stages. In a similar manner, a field-supplied 4 to 20 mA signal can also be used to reduce the total capacity of the chillers.

Hot gas bypass

The hot gas bypass provides an additional stage of capacity control below the minimum standard step of capacity.

Capacity control steps

Refer to the Capacity Control Steps table below for capacity control steps for standard units.

NOTE: If the optional factory-installed hot gas bypass is used, one more stage of unloading will be added and the units will be able to operate with an additional step of capacity.

CAPACITY CONTROL STEPS

UNIT 30MP	CONTROL STEPS	PERCENT DISPLACEMENT
015	1	18*
	2	50
	3	100
020	1	25*
	2	50
	3	100
030	1	34*
	2	50
	3	100
040	1	21*
	2	33
	3	67
	4	100
045	1	22*
	2	33
	3	67
	4	100
050	1	40*
	2	50
	3	100
055	1	35*
	2	44
	3	100
060	1	33*
	2	42
	3	100
065	1	31*
	2	38
	3	100
071	1	38*
	2	44
	3	100

* Optional hot gas bypass.

NOTE: For digital compressor, see pages 6 and 8.

Typical piping and wiring

LIQUID-COOLED 30MPW SHOWN

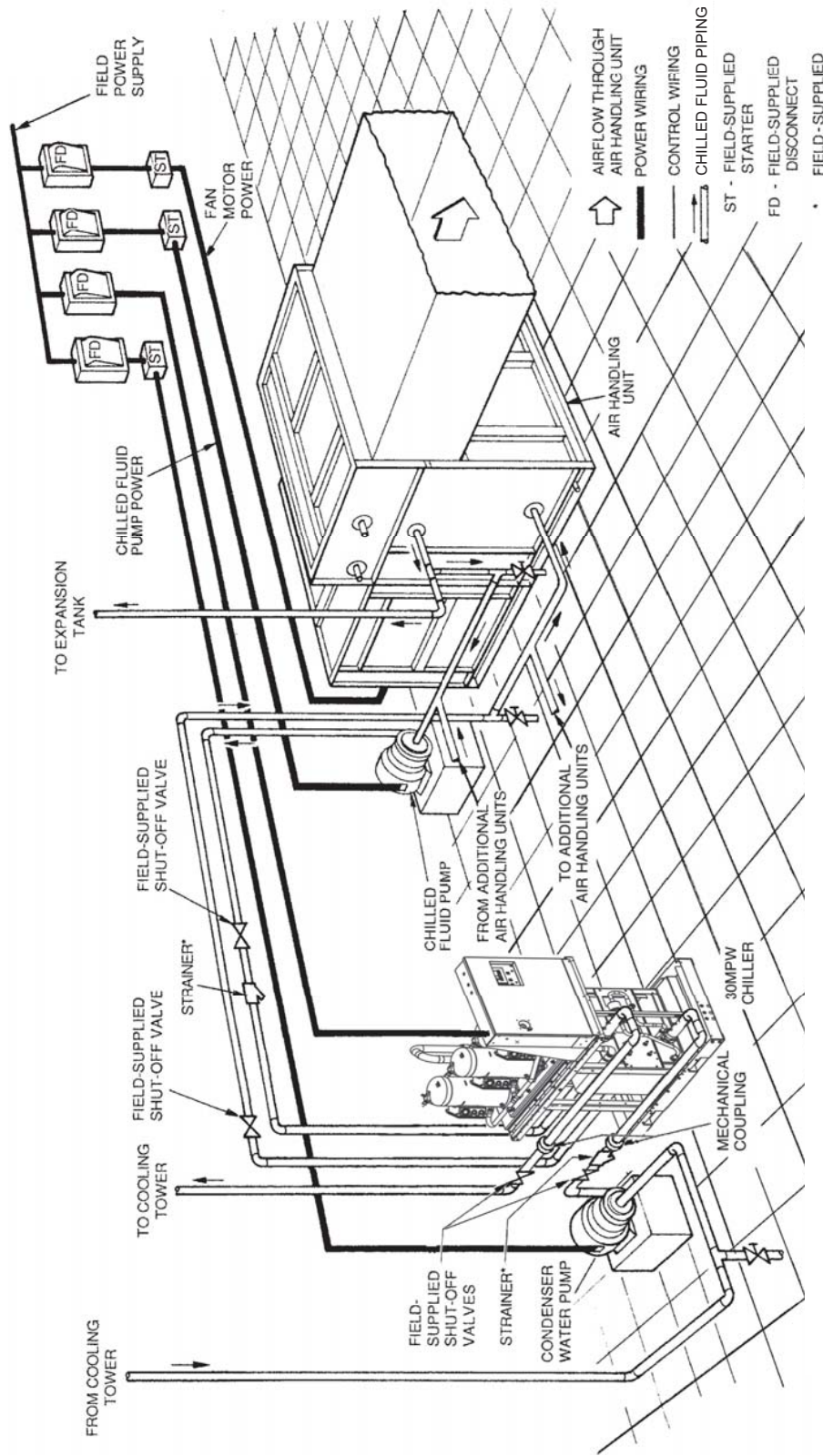

NOTES:

1. Chiller must be installed levelly to maintain proper compressor oil return.
2. Wiring and piping shown are general points-of-connection guides only and are not intended for a specific installation. Wiring and piping shown are for a quick overview of system and are not in accordance with recognized standards.
3. All wiring must comply with applicable local and national codes.
4. All piping must follow standard piping techniques. Refer to Carrier System Design Manual or appropriate ASHRAE (American Society of Heating, Refrigerating, and Air-Conditioning Engineers) handbook for details.
5. See Application Data section on page 22 for minimum system fluid volume. This system may require the addition of a holding tank to ensure adequate volume.
6. Operating environment — Chiller should be installed in an indoor environment where the ambient temperature is between 50 and 104 F (10 and 40 C) with a relative humidity (non-condensing) of 95% or less. To ensure that electrical components operate properly, do not locate the chiller in an area exposed to dust, dirt, corrosive fumes, or excessive heat and humidity.

30MPA UNIT WITH 09DP REMOTE AIR-COOLED CONDENSER SHOWN

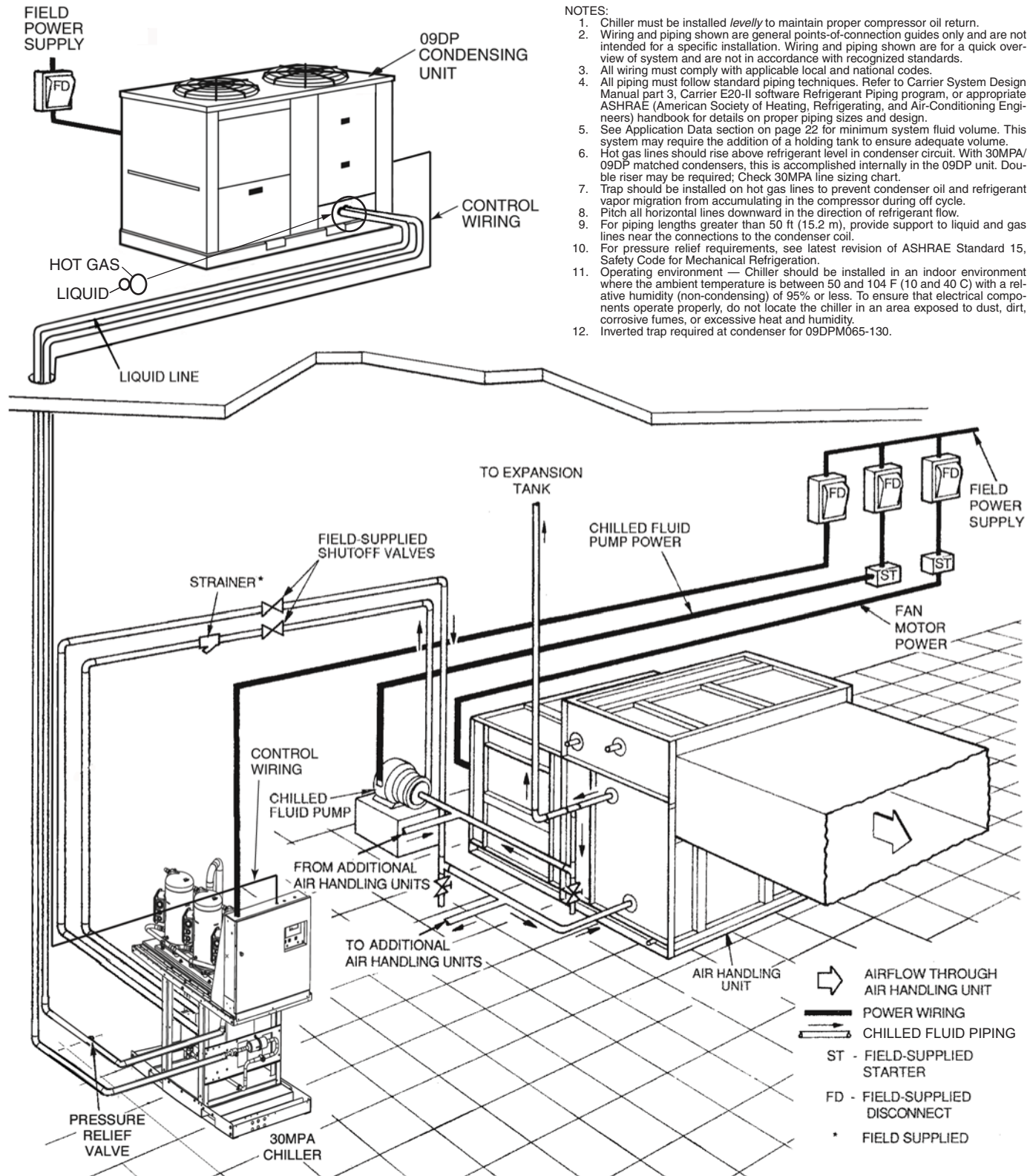

- NOTES:**
1. Chiller must be installed *levelly* to maintain proper compressor oil return.
 2. Wiring and piping shown are general points-of-connection guides only and are not intended for a specific installation. Wiring and piping shown are for a quick overview of system and are not in accordance with recognized standards.
 3. All wiring must comply with applicable local and national codes.
 4. All piping must follow standard piping techniques. Refer to Carrier System Design Manual part 3, Carrier E20-II software Refrigerant Piping program, or appropriate ASHRAE (American Society of Heating, Refrigerating, and Air-Conditioning Engineers) handbook for details on proper piping sizes and design.
 5. See Application Data section on page 22 for minimum system fluid volume. This system may require the addition of a holding tank to ensure adequate volume.
 6. Hot gas lines should rise above refrigerant level in condenser circuit. With 30MPA/09DP matched condensers, this is accomplished internally in the 09DP unit. Double riser may be required; Check 30MPA line sizing chart.
 7. Trap should be installed on hot gas lines to prevent condenser oil and refrigerant vapor migration from accumulating in the compressor during off cycle.
 8. Pitch all horizontal lines downward in the direction of refrigerant flow.
 9. For piping lengths greater than 50 ft (15.2 m), provide support to liquid and gas lines near the connections to the condenser coil.
 10. For pressure relief requirements, see latest revision of ASHRAE Standard 15, Safety Code for Mechanical Refrigeration.
 11. Operating environment — Chiller should be installed in an indoor environment where the ambient temperature is between 50 and 104 F (10 and 40 C) with a relative humidity (non-condensing) of 95% or less. To ensure that electrical components operate properly, do not locate the chiller in an area exposed to dust, dirt, corrosive fumes, or excessive heat and humidity.
 12. Inverted trap required at condenser for 09DPM065-130.

Typical piping and wiring (cont)

MANIFOLD 30MPA UNITS WITH DUAL CIRCUIT 09DP REMOTE AIR-COOLED CONDENSER SHOWN

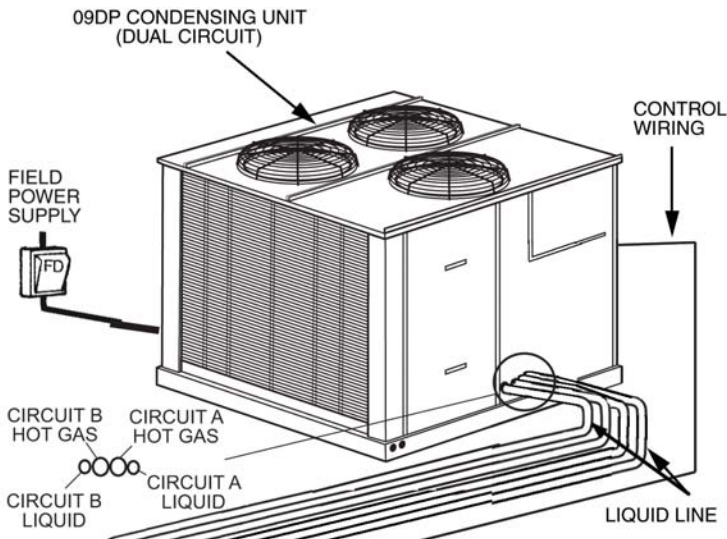

- NOTES:
1. Chiller must be installed *levelly* to maintain proper compressor oil return (level adjustment kit included with manifold piping kit (option)).
 2. Wiring and piping shown are general points-of-connection guides only and are not intended for a specific installation. Wiring and piping shown are for a quick overview of system and are not in accordance with recognized standards.
 3. All wiring must comply with applicable local and national codes.
 4. All piping must follow standard piping techniques. Refer to Carrier System Design Manual part 3, Carrier E20-II software Refrigerant Piping program, or appropriate ASHRAE (American Society of Heating, Refrigerating, and Air-Conditioning Engineers) handbook for details on proper piping sizes and design.
 5. See Application Data section on page 22 for minimum system fluid volume. This system may require the addition of a holding tank to ensure adequate volume.
 6. Hot gas lines should rise above refrigerant level in condenser circuit. With 30MPA/09DP matched condensers, this is accomplished internally in the 09DP unit. Double riser may be required; Check 30MPA line sizing chart.
 7. Trap should be installed on hot gas lines to prevent condenser oil and refrigerant vapor migration from accumulating in the compressor during off cycle.
 8. Pitch all horizontal lines downward in the direction of refrigerant flow.
 9. For piping lengths greater than 50 ft (15.2 m), provide support to liquid and gas lines near the connections to the condenser coil.
 10. For pressure relief requirements, see latest revision of ASHRAE Standard 15, Safety Code for Mechanical Refrigeration.
 11. Operating environment — Chiller should be installed in an indoor environment where the ambient temperature is between 50 and 104 F (10 and 40 C) with a relative humidity (non-condensing) of 95% or less. To ensure that electrical components operate properly, do not locate the chiller in an area exposed to dust, dirt, corrosive fumes, or excessive heat and humidity.
 12. Inverted trap required at condenser for 09DPM065-130.

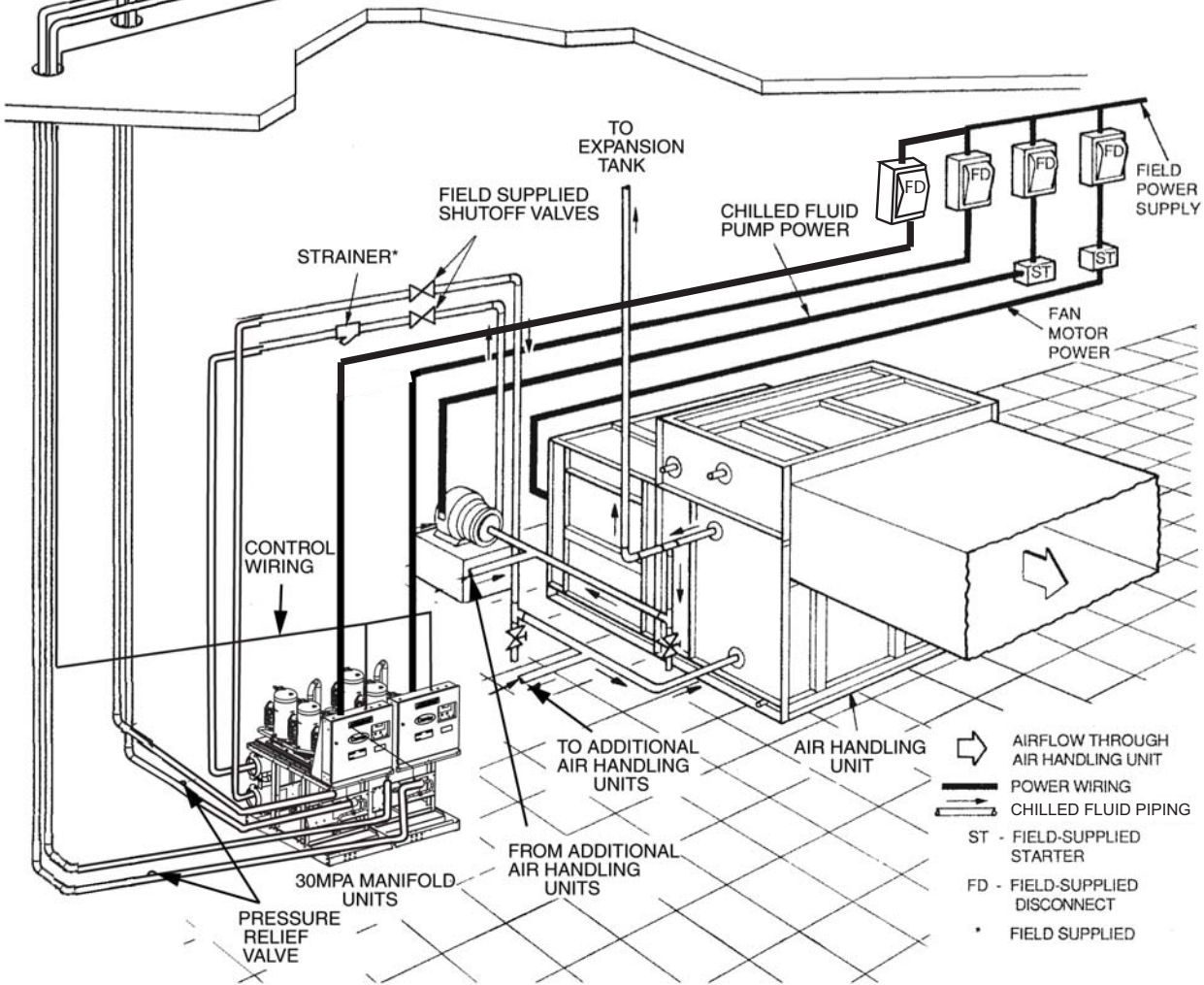

Typical control wiring schematic

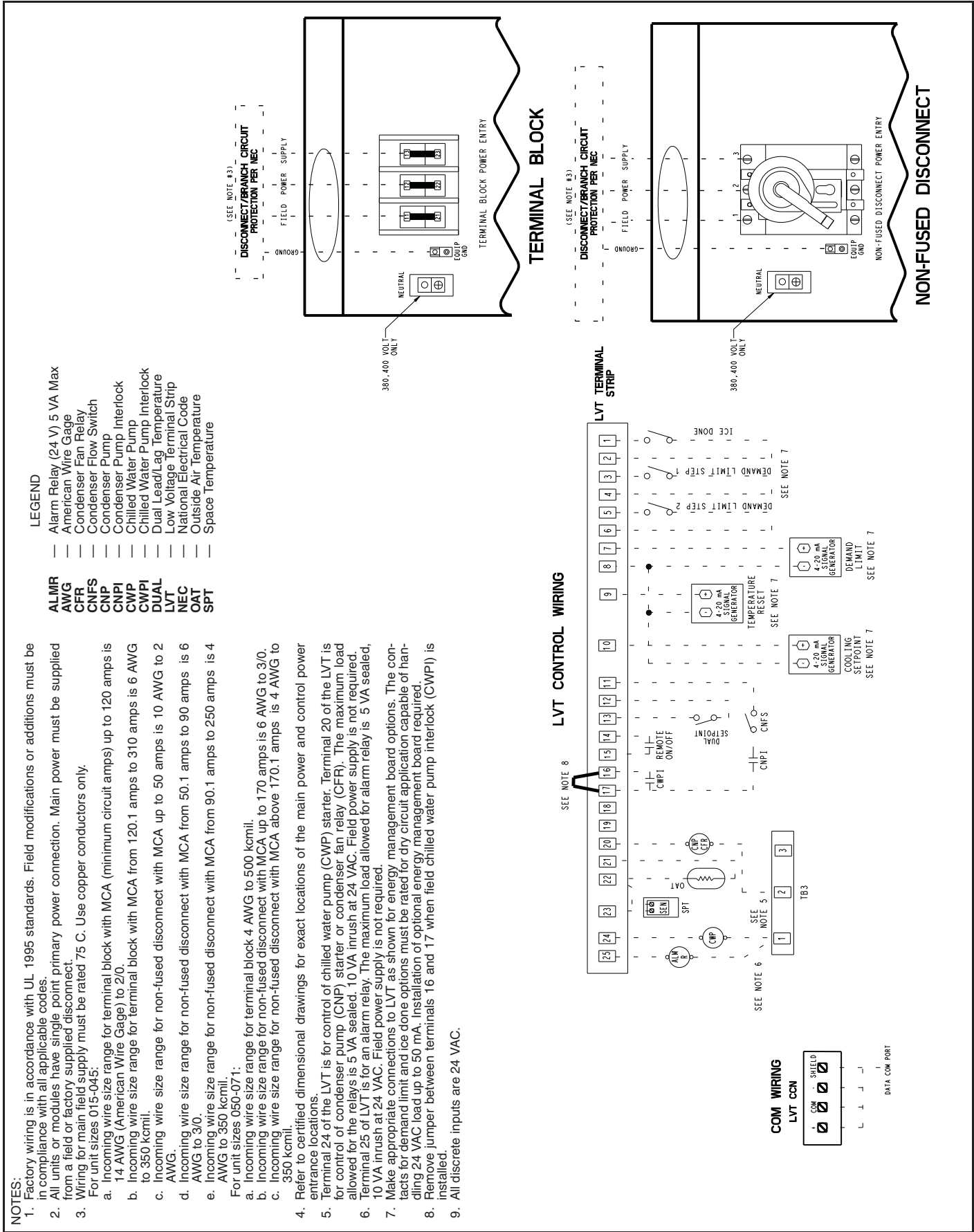

Guide specifications



Scroll Liquid Chillers

HVAC Guide Specifications

Size Range: **15 to 71 Tons (53 to 250 kW)**

Carrier Model Numbers:

30MPA,MPW

Part 1 — General

1.01 SYSTEM DESCRIPTION

Microprocessor controlled liquid-cooled condenser (30MPW) or condenserless (30MPA) liquid chiller utilizing scroll type compressors.

1.02 QUALITY ASSURANCE

- A. Unit performance shall be rated per AHRI (Air-Conditioning, Heating and Refrigeration Institute) Standard 550/590 and 551/591, latest edition (U.S.A.) at standard rating conditions.
- B. All units shall be ASHRAE (American Society of Heating, Refrigerating and Air-Conditioning Engineers) 90.1 compliant.
- C. Unit construction shall comply with ANSI (American National Standards Institute)/ASHRAE 15 Safety Standard (latest revision) and NEC (National Electrical Code).
- D. Unit shall be certified in accordance with ISO (International Organization for Standardization) 9001 manufacturing quality standard.
- E. Unit shall be ETL and ETL, Canada certified.

1.03 DELIVERY, STORAGE AND HANDLING

- A. Unit shall be shipped factory-assembled with all piping and wiring, precharged with a complete operating charge of R-410A (30MPW) or a holding charge of nitrogen (30MPA) and shall be stored and handled according to manufacturer's recommendations.
- B. Unit controls shall be capable of withstanding 150 F (66 C) storage temperatures in the control compartment.
- C. Chiller and starter should be stored indoors, protected from construction dirt and moisture. An inspection should be conducted under shipping tarps, bags, or crates to be sure water has not collected during transit. Protective shipping covers should be kept in place until machine is ready for installation. The inside of the protective cover should meet the following criteria:
 - 1. Temperature is between 40 F (4.4 C) and 120 F (48.9 C).
 - 2. Relative humidity is between 10% and 80% (non-condensing).

Part 2 — Products

2.01 EQUIPMENT

- A. General:

Single-piece liquid chiller consisting of compressor(s), BPHE (brazen-plate heat exchanger) evaporator, condenser (30MPW only), controls, safeties, and any hardware required before start-up.

B. Unit Cabinet:

- 1. Frame shall be of heavy-gage galvanized steel with an electrostatically applied baked enamel finish.
- 2. The unit shall pass through a standard 36-in. (914 mm) door and shall not exceed 57 in. (1448 mm) in length.

C. Compressor:

- 1. Fully hermetic scroll type compressors.
- 2. Direct drive, 3500 rpm (58 r/s), protected by line break device, suction gas cooled motor.
- 3. External vibration isolation - rubber in shear.
- 4. Staging of compressors shall provide unloading capability. Digital compressor unloading is optional.

D. Evaporator:

- 1. Evaporator shall be rated for a maximum refrigerant pressure of 505 psig (3482 kPa) for sizes 015 and 020, 565 psig (3896 kPa) for sizes 030 to 045, and 653 psig (4506 kPa) for sizes 050 to 071, and shall be tested for a maximum water-side pressure of 300 psig (2068 kPa).
- 2. Shall be single-pass, ANSI type 316 stainless steel, brazed plate construction.
- 3. Shall be insulated with ³/₄-in. (19 mm) closed-cell, polyvinyl-chloride foam with a maximum K factor of 0.28.
- 4. Unit shall be provided with a factory-installed flow switch.
- 5. Unit shall be provided with entering and leaving chilled water temperature sensors and water pressure access port.
- 6. A strainer with a minimum of 40 mesh must be installed within 10 ft (3 m) of the heat exchanger fluid inlet to prevent debris from clogging the heat exchanger. This strainer shall be required and shall be available as an accessory.

E. Brazed-Plate Condenser:

- 1. Condenser shall be rated for a maximum refrigerant pressure of 505 psig (3482 kPa) for sizes 015 and 020, 565 psig (3896 kPa) for sizes 030 to 045, and 653 psig (4506 kPa) for sizes 050 to 071, and shall be tested for a maximum water-side pressure of 300 psig (2068 kPa).
- 2. Single-pass, liquid-cooled, ANSI type 316, stainless-steel brazed-plate construction that shall provide positive subcooling of liquid refrigerant.
- 3. Unit shall be equipped with Victaulic water connections.
- 4. A strainer with a minimum of 40 mesh must be installed within 10 ft (3 m) of heat exchanger fluid inlet to prevent debris from clogging the heat exchanger. This strainer shall be required and shall be available as an accessory.

F. Refrigerant Components:

1. Each chiller shall contain the following: sight glass; filter drier; liquid line solenoid valve (30MPA); liquid line isolation valve (30MPA); expansion valve; and charging port.
2. Expansion valve (TXV [thermostatic expansion valve] unit sizes 015-045, EXV [electronic expansion valve] unit sizes 050-071) shall be located within 12 in. of the evaporator with no bend between expansion valve and evaporator in accordance with evaporator manufacturer recommendation.

G. Controls, Safeties and Diagnostics:

1. Controls:

- a. Unit controls shall include the following minimum components:
 - 1) Microprocessor.
 - 2) Power and control circuit terminal blocks.
 - 3) ON/OFF control switch.
 - 4) Thermistor is installed to measure evaporator entering and leaving fluid temperatures.
 - 5) Terminal block for temporary and/or permanent interface to the Carrier Comfort Network® or similar building system control.
- b. Microprocessor with non-volatile memory. Battery backup system shall not be accepted.
- c. Control transformer to serve all controllers, contactors, relays, and control components.
- d. Replaceable solid-state relay panels and controllers.
- e. Pressure transducers (used to calculate saturated suction temperature and saturated condensing temperature).
- f. Provision for field installation of accessory sensor to measure compressor return gas temperature (suction gas thermistor) (unit sizes 015-045 only).
- g. Terminals shall be provided in the control box for wiring of accessory field-installed condenser temperature sensors.
- h. Unit controls shall be capable of performing the following functions:
 - 1) Capacity control based on leaving chilled fluid temperature and compensated by rate of change of return-fluid temperature.
 - 2) Limiting of the chilled fluid temperature pulldown rate at start-up to 1° F (0.56° C) per minute to prevent excessive demand spikes (charges) at start-up.
 - 3) Seven-day time schedule.
 - 4) Leaving chilled fluid temperature reset from return fluid.

- 5) Dual chiller control for parallel chiller applications (common leaving chilled water sensor required).
- 6) Timed maintenance scheduling to signal maintenance activities.

2. Diagnostics:

- a. The control panel shall include, as standard, a scrolling marquee display capable of indicating the safety lockout condition by displaying a code for which an explanation may be scrolled at the display.
- b. Information included for display shall be:
 - 1) Compressor lockout.
 - 2) Loss of charge.
 - 3) Low fluid flow.
 - 4) Evaporator freeze protection.
 - 5) Thermistor malfunction.
 - 6) Entering and leaving-fluid temperature.
 - 7) Circuit suction and discharge pressure.
 - 8) Time of day.
- c. Display module, in conjunction with the microprocessor, must also be capable of displaying the output (results) of a service test. Service test shall verify operation of every switch, thermistor, and compressors before chiller is started.
- d. Diagnostics shall include the ability to review a list of the 20 most recent alarms with clear language descriptions of the alarm event. Display of alarm codes without the ability for clear language descriptions shall be prohibited.
- e. An alarm history buffer shall allow the user to store no less than 20 alarm events with clear language descriptions, time and date stamp event entry.
- f. The chiller controller shall include a connection port for communicating with the local equipment network and the Carrier Comfort Network (CCN) system.
- g. The control system shall allow software upgrade without the need for new hardware modules.

3. Safeties:

- a. Unit shall be equipped with sensors and all necessary components in conjunction with the control system to provide the unit with the following protections:
 - 1) Loss of refrigerant charge protection.
 - 2) Low fluid flow detection.
 - 3) Low chilled fluid temperature protection.
 - 4) Low control voltage (to unit) protection.
 - 5) High-pressure switch.
 - 6) Reverse rotation.
 - 7) Overcurrent protection.
 - 8) Loss of phase.

Guide specifications (cont)



b. Compressors shall be equipped with the following protections:

- 1) High discharge temperature protection.
- 2) Electrical overload through the use of definite-purpose contactors and motor overload protection through internal compressor overload or external current overload.
- 3) Circuit breakers shall open all 3 phases in the event of an overload in any one phase (single-phasing condition).
- 4) Circuit breakers for short circuit protection.

H. Operating Characteristics:

1. Unit shall be capable of starting with up to 95 F (35 C) fluid temperature entering the evaporator.
2. Unit shall be capable of operating with variable evaporator fluid flow, up to 10% change in flow rate per minute.

I. Electrical Requirements:

1. Single-point electrical power connection with compressors factory-wired to a terminal block in the control panel. Compressor sensors and system pressure transducers shall be factory-wired to the unit controller.
2. Control interface shall be accessed through low voltage terminal strip or terminal strip.

J. Chilled Water Circuit:

1. Chilled water circuit shall be rated for 300 psig (2068 kPa).
2. Solid-state flow switch with integral relay shall be factory installed and wired.

K. Special Features:

Certain standard features are not applicable when the features designated by * are specified. For assistance in amending the specifications, contact your Carrier representative.

1. Hot Gas Bypass:

This factory-installed option shall permit chiller to provide an additional step of capacity reduction over standard.

2. Sound Enclosure Panels:

This acoustic package shall be either factory-installed or field-installed and shall entirely enclose the compressor section to further reduce radiated sound.

3. Mobility Kit (Wheels):

This package shall be factory-supplied for field installation and shall include 6 swivel wheels for easy unit mobility.

4. Height Adjustment Kit:

The units shall be shipped with a high adjustment mechanism located in each corner of the unit to aid in leveling the chiller and to facilitate connections to existing piping.

5. Vibration Isolators (Resilient Pads):

Vibration isolators shall be field-installed before the unit is set into its final location and shall reduce vibration transmission through the mounting area of the chiller.

6. Vibration Isolators (Springs):

Vibration isolators shall be field-installed before the unit is set into its final location and shall reduce vibration transmission through the mounting area of the chiller.

7. Non-Fused Disconnect:

The non-fused disconnect shall be factory installed and shall disconnect all power to the unit (including control circuit power).

8. Brine:

a. Special modifications shall be made at the factory to permit operation with leaving chilled fluid temperatures between 15 and 32 F (-9.4 and 0.0° C).

b. Unit shall be provided with a factory-installed liquid line solenoid (per refrigerant circuit) to be used in medium temperature brine and condenserless applications.

9. Strainer:

A Y strainer shall be available in sizes 1.5 to 6 in. with a minimum of 40 mesh for field installation.

10. Remote Enhanced Display:

Unit shall be supplied with indoor-mounted, remote, 40-character per line, 16-line display panel for field installation.

11. Energy Management Module (EMM):

A factory or field-installed module shall provide the following energy management capabilities: 4 to 20 mA signals for leaving fluid temperature reset, cooling set point or demand limit control; 2-point demand limit control (from 15% to 100%) activated by a remote contact closure; and discrete input for "Ice Done" indication for ice storage system interface.

EMM shall be capable of:

a. Leaving temperature reset from space temperature, outdoor temperature, or 4 to 20 mA signal.

b. Demand limit or load shed via field-supplied 4 to 20 mA signal or 2-step discrete contact closure.

12. BACnet Translator Control:

Unit shall be supplied with field-installed interface between the chiller and a BACnet Local Area Network (LAN, i.e., MS/TP EIA-485).

13. LON Translator Control:

Unit shall be supplied with field-installed interface between the chiller and a Local Operating Network (LON, i.e., LonWorks FT-10A ANSI/EIA-709.1).

14. Navigator™ Hand Held Display Module:
 - a. Portable hand held display module with a minimum of 4 lines and 20 characters per line, or clear English, Spanish, Portuguese or French language.
 - b. Display menus shall provide clear language descriptions of all menu items, operating modes, configuration points and alarm diagnostics. Reference to factory codes shall not be accepted.
 - c. RJ-14 connection plug shall allow display module to be connected to factory-installed receptacle.
 - d. Industrial grade coiled extension cord shall allow the display module to be moved around the chiller.
 - e. Magnets shall hold the display module to any sheet metal panel to allow hands-free operation.
 - f. Display module shall have NEMA 4x housing suitable for use in outdoor environments.
 - g. Display shall have back light and contrast adjustment for easy viewing in bright sunlight or night conditions.
 - h. Raised surface buttons with positive tactile response.
15. Digital Compressor Option:

Shall provide factory-installed digital compressor to provide additional steps of capacity (not available on sizes 015, 050-071).
16. Compressor Insulation:

Compressor insulation is designed to insulate scroll compressors and prevent water vapor from condensing on the colder compressor surface.
17. High Interrupt Option:

Shall provide factory-installed high interrupt option that gives the chiller a short-circuit current rating of 65 kA (100 kA for 575-v size 015-045 units, 25 kA for 575-v size 050-071 units).
18. Compressor Sound Blankets:

Units can be ordered with acoustically insulated sound blankets installed around the compressors to reduce radiated sound levels.
19. Water Manifold Piping Option:

Shall provide piping that allows more than one 30MP chiller module to be piped together in parallel. Combination valves shall also be provided.
20. BACnet Communication Option:

Shall provide factory-installed communication capability with a BACnet MS/TP network. Allows integration with i-Vu® Open control system or a BACnet building automation system.

